

Electro Industries' Buffer Tank Controller

Installation & Operating Instructions Models HP-BTC, HP-BTC-24

Application

- Correctly controls and balances up to 8 hydronic heating zones plus 1 heating/cooling forced air water coil.
- Supplies heat/cool "call" to Northern Heat Pump geothermal systems, Electro Industries' NorAire[®] system, or any manufacturer's Water to Water geothermal heat pump.
- This product conforms to UL standard 873
- This product conforms to CSA Standard C22,2



Drawings: **HX101**
HH120
HH121
XX017

DO NOT DESTROY THIS MANUAL. PLEASE READ CAREFULLY AND KEEP IN A SAFE PLACE FOR FUTURE REFERENCE BY A SERVICE TECHNICIAN.



ELECTRO INDUSTRIES, INC.
2150 West River Street, PO Box 538, Monticello, MN 55362
763.295.4138 • 800.922.4138 • fax 763.295.4434
sales@electromn.com • www.electromn.com

Table of Contents

Introduction	1
Safety Considerations	1
Product Configurator	2
Electrical Data	2
Installation Overview	3
Installation and Hookup	3
Controller Setup	6
V2.00 Setup/Programming	12
Buffer Tank Operation	16
Troubleshooting	19
Drawings	HX101 HH120 HH121 XX017

Introduction

The use of a buffer tank and controller is an important part of most water-to-water or air to water heat pump applications, particularly if a combination of a forced air coil and hydronic zones are utilized. Choosing the right buffer tank controller is important, as the correct controller can make a big difference in efficiency and in the smooth operation of the entire heat pump system. Electro Industries' Buffer Tank Controller utilizes many features you won't find on most controllers. Outdoor reset (the sensing and utilization of the outdoor temperature to determine tank target temperature), easy set-up, dual fuel system interfacing and solid design are just a few of the features you will appreciate in this controller.

Other Features:

Control forced air water coils plus up to eight hydronic zones with one controller
Digital or Standard Thermostat Compatible
Fuse Protected, Control Board and Zone Valve Connections
Onboard LED troubleshooting lights indicate stat calls and pump power for each individual zone
Remote Data Communication between the hydronic board and buffer tank controller
All pumps powered from the controller simplifies wiring
Model HP-BTC features 120VAC outputs.
Model HP-BTC-24 features 24VAC outputs

Compatibility:

Although most of the drawings in this manual represent Northern Heat Pump North Star Series heat pumps, this buffer tank controller can be easily incorporated into any manufacturers' water to water heat pump system.

Heating/Cooling

The Buffer Tank Controller will satisfy heat calls utilizing a forced air water coil (if present) and the hydronic water loops. The controller will satisfy a chilled water call (cooling) using the forced air coil loop only. The Buffer Tank Controller will not send chilled water through the hydronic loops.

Initial Inspection

Be certain to inspect all cartons and crates as units are received before signing the freight bill. Verify that all items received have no physical damage. Report any damage or shortages on the freight bill. The purchaser is responsible for filing the necessary claims with the carrier. Concealed or hidden damages not discovered until removing packaging must be reported to the carrier within 15 days of receipt.

Unit Location and Mounting

Locate the unit on a dry indoor wall near the buffer tank. There are 4 mounting holes in the rear of the Buffer Tank Controller cabinet. Using proper fasteners (not provided), utilize these mounting holes to secure the cabinet to the wall of the structure.

Safety Considerations

WARNING

BEFORE PERFORMING SERVICE OR MAINTENANCE OPERATIONS ON A SYSTEM, TURN OFF MAIN POWER SWITCHES TO THE INDOOR UNITS. IF APPLICABLE, TURN OFF THE ACCESSORY HEATER POWER SWITCH. ELECTRICAL SHOCK COULD CAUSE PERSONAL INJURY.

Installing and servicing heating and air conditioning equipment can be hazardous due to system pressure and electrical components. Only trained and qualified service personnel should install, repair or service heating and air conditioning equipment. When working on heating and air conditioning equipment, observe precautions in the literature, tags and labels attached to the unit and other safety precautions that may apply, such as the following safety measures:

- Follow all safety codes.
- Wear safety glasses and work gloves.

Product Configurator

HP-BTC-*

None = 120V
24 = 24V

Electrical Data

Model	Voltage	Static Amps	Maximum Load Amps*	Maximum Source
HP-BTC	120	0.20	9.8	15
HP-BTC-24	24	0.1	0.77	5.0

*Application/field installation determines zone controlling components activated by this controller.

Installation Overview

This controller contains interface/logic devices, a buffer tank (BT) sensor, and an outdoor temperature (OT) sensor. Based on the application, many other system components may be required to make your system operate as desired. These components must be provided by the installing contractor. These components may include but are not limited to:

- a geothermal or air-to-water heat pump
- a listed buffer tank
- water coil(s) and blowers (in the case of a forced air system)
- system pumps
- expansion tank and air eliminator
- hydronic valves and piping
- thermostats
- wiring
- transformer
- pump relays

Refer to the HX101 diagrams in this manual which show various system configurations.

Installation and Hookup

Controller Power

A detailed hookup drawing (HH120) is included in this manual. A qualified electrician should perform all high-voltage wiring tasks on this unit.

120V hookup – Model HP-BTC

120 VAC with a minimum of 10 amps of dedicated power is required to power the Electro Industries Buffer Tank Controller model HP-BTC. We recommend wiring this product in such a way that power comes directly from the power panel to the terminal block located inside of the lower half of the buffer tank controller enclosure. Various “knockouts” in the controller’s enclosure are included for your use and convenience. Do not apply power to the unit until full installation is complete.

24V Hookup – Model HP-BTC-24

The HP-BTC-24 unit will not include a transformer. The controller requires 24VAC from another power source (heat pump, air handler, gas furnace or boiler) to power the control boards internal to the Buffer Tank Controller. In this scenario, the zone output block will output 24VAC meaning all pumps will require one isolation relay per pump.

Multiple System Transformers

In some installations, multiple transformers exist (such as in the furnace or air handler, heat pump, and others) in the HVAC system. Refer to the installation manuals for these products to determine if multiple transformer compatibility issues may occur.

<p>IMPORTANT: MULTIPLE TRANSFORMERS IN THE SAME HVAC SYSTEM ARE KNOWN TO CAUSE SYSTEMS TO MALFUNCTION. PLEASE REFER TO THE HOOKUP DIAGRAMS AT THE END OF THIS MANUAL FOR THE CORRECT HOOKUP CONFIGURATION FOR YOUR PARTICULAR SYSTEM.</p>
--

Note:

- Model HP-BTC does include a transformer
- Model HP-BTC-24 does not include a transformer

This manual does include detailed suggested wiring for all instances with regards to low voltage wiring.

Fuses

The circuit boards and all external field connections/wiring are fuse protected with a self-resetting 3-amp fuse.

Gas furnace – if this is a “dual fuel” installation including a gas or oil backup furnace, only two wires are required between this controller and the gas furnace. It is assumed the gas furnace logic will control its own

blower based upon a gas-W heating call.

Gas or Electric Boilers – Only two wires are required between this controller and the auxiliary boiler. It is assumed the boiler's logic will control its own pumps based upon a gas-W heating call.

Thermostats

In all applications, there will be a necessity to interface thermostats for hydronic heating zones. There is also a possibility that the HVAC system design will include a requirement to service forced air load. If this is the case, there will be a requirement for hydronic thermostat hookup and forced air thermostat hookup. Below is information on required thermostats for each heating system type.

Note: If no forced air load exists within the make up of this HVAC system, disregard the comments on forced air hookup.

Forced Air Thermostat Information

1. To service the forced air coil loop, this Buffer Tank Controller requires a conventional heat/cool, 1H/1C, 4-wire thermostat. This thermostat will connect to the upper right hand corner of the logic controller terminal labeled "STAT".
2. In all forced air applications, a connection must be made between all thermostat terminals – R,W,G,Y

Hydronic Thermostat Hookup

1. Connect the slab stat or temperature sensing thermostat wires coming from the hydronic zones to the top terminal block "R" and the numbered "W" terminal block located on the zone control circuit board. If using Electro-Stat, a "Common" is required at each Electro-Stat. Connect the thermostat serving the forced air coil loop to the "stat" terminal block located on the control board. Drawings included in this manual show typical hookups for various thermostats. Connect per your selected thermostat.
2. If using hydronic priority feature, zone 1 and connected stat 1 must be the priority zone.
3. This buffer tank controller is not compatible with power robbing thermostats.

Thermostat Heat Anticipator/CPH Setting

If your thermostat has an anticipator setting, set the anticipator to 0.2 or less. If your thermostat has a "cycles per hour" setting, set it to 2 cycles per hour.

Buffer Tank Sensors:

Included with this buffer tank controller are two sensors. One buffer tank sensor (BT) and one outdoor sensor (OT). The Outdoor Sensor (OT) and the buffer tank temperature (BT) sensor are wired into a common connection plug. Below is instruction and a description of each:

Outdoor Sensor (OT)

Extend OT sensor to an outdoor location properly sampling the outdoor temperature. Select a location away from direct sunlight and where the sensor will not pick up false temperature from the heat pump outdoor unit, refrigerant line sets, dryer vent, reflection off of steel siding, etc. Do not install the sensor in any type of enclosure, as this will falsely trap and pick up radiant sun temperature. Mount the sensor horizontally on the structure using the screws provided.



Buffer Tank Temperature (BT) Sensor

Install the Buffer Tank Temperature (BT) Sensor in the buffer tank. To obtain an accurate temperature sample, the sensor should be placed in the center of the tank. If the temperature sensor is being installed in an Electro Industries buffer tank, the location of the tank fittings ensure the sensor is properly located. For easy sensor cable disconnect and reconnect, the control board is equipped with a plug-in 4-place terminal block.

Temperature Sensor Plug

Before disconnecting the temperature sensor wires from the sensor plug, you will notice two red wires are under the red screw and two white wires is under the COM screw. The black wire carries data information from each sensor and must be connected to the appropriate OT (Outdoor Temperature) or ST (Buffer Tank Temperature) screw. The sensor has a specific polarity and is sensitive to incorrect voltage, so it must be protected from incorrect voltages. Do not cross connect or inadvertently short out sensor wires with power on. Permanent sensor damage may result. If the installation requires you to disassemble and reassemble the wiring to the plug, take great care duplicate the original wiring exactly.

Other Sensor Related Comments

If additional cable length is required, you must use the following rules for extending the cable.

- Use unshielded (low capacitance, preferred twisted) 3 or 4-wire low voltage cable.
- 50 (15 meters) feet is maximum (total) wire length.
- Do not, under any circumstances, use leftover wires within the normal thermostat cable.
- Route the sensor cable making sure you do not crimp, cut, staple, or damage the cable in any way.
- Keep sensor cables at least 12" (30 cm) away from any line voltage wiring, romex, etc.

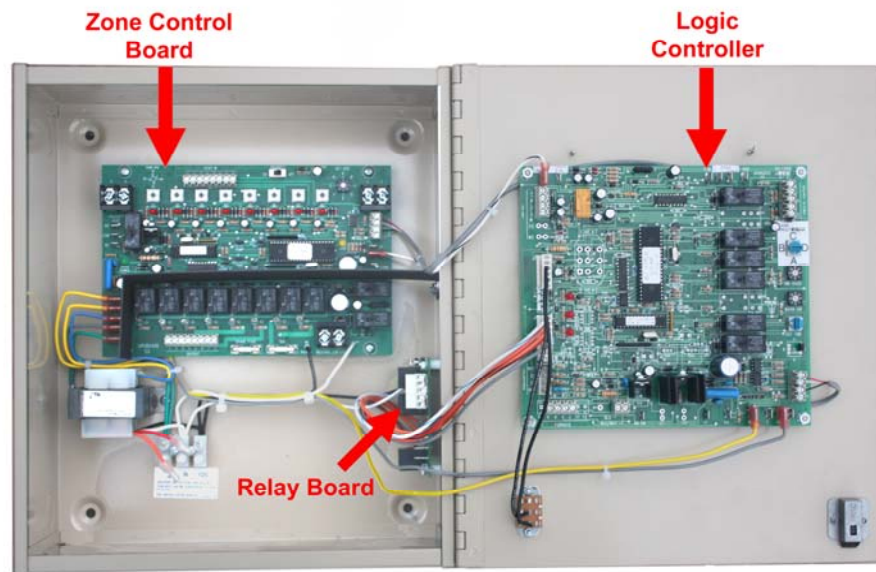

Circuit Boards

Inside the Electro Industries Buffer Tank Controller's cabinet, you will find 3 circuit boards:

1. Located on the hinged door is the system controller board which makes all logic decisions as well as interfaces the heat pump, standby heat source (if applicable) and forced air room thermostat (if applicable)
2. A small relay circuit board, which interfaces and controls the main pump and A-Coil Pump, is located on the side panel.
3. A larger zone control board which interfaces the hydronic zone thermostats and zone pumps is located on the rear of the cabinet.

All system adjustments will take place on the system controller circuit board.

UNDERSTANDING OUR TERMINOLOGY REGARDING “ZONES” – IN AN ATTEMPT TO CLEARLY DESCRIBE THE FUNCTION AND FEATURES OF THE BUFFER TANK CONTROLLER, THIS MANUAL REFERS TO THE FORCED AIR WATER COIL LOOP AND THE HYDRONIC HEATING ZONES AS SEPARATE APPARATUSES. WE DO NOT CONSIDER THE FORCED AIR COIL A “ZONE”.

Function of the Buffer Tank During Heat Calls vs. Chilled Water Calls

The hydronic zones are enabled in heating mode only. The hydronic zones will not respond to a “Y” (cooling) call from the thermostat. The cooling function will be performed by the forced air water coil only.

NOTE: Not all installations will have a cooling load.

Zoning Pumps – HP-BTC

1. The 120-volt source for the zone pumps is derived from the same external 120V source used to power the transformer. Therefore, the board connectors labeled “OUPUT” are energized (L1) and ready to be used with zone pumps.
2. The “common” connections of each zone pump are tied together back to neutral on the zone control board.
3. Pump circuits are protected with a 10-amp fuse located on the zone control board.

Zone Valves – HP-BTC-24

1. The 24VAC source for the zone valves is derived from the same external 24VAC source used to power the transformer. Therefore, the board connectors labeled “OUPUT” are energized (24VAC) and ready to be used with zone valves
2. The “common” connection of each zone valve are tied together back to common on the zone control board.

Hydronic Zone Priority – Zone 1 Only

Located on the top right corner of the hydronic zone controller is a switch labeled “priority”. With priority switch in the ON position, all heating resources are dedicated to hydronic zone 1. The remaining hydronic zones, along with the forced air coil, are operational only when hydronic zone 1 is satisfied.

Note that during priority mode, furnace G is interrupted and no heat is being delivered to the forced air coil during active hydronic zone 1 heat demand. With the priority switch in the “off” position, all zones plus the forced air coil are considered equal.

Forced Air Priority Timer

The right-hand side of the system control board has a set of jumper pins labeled SW8. The jumper is engaged as it ships from the factory. Used “as is”, the forced air water coil is treated the same as a hydronic zone during the heating season. Removal of this jumper will initiate the start of an internal timer whenever the control board receives a heat call from the forced air thermostat. At the conclusion of the timer period, the Buffer Tank Controller will stop service to all hydronic zones in order to allocate 100% of the buffer tank resources to the forced air coil for the remainder of the forced air call. The timer may be adjusted with the use of a PC computer. Special software and a dedicated data cable are required to accomplish this. The “Buffer Tank Controller software” and cable are available from Electro Industries. With the use of this software, the timer may be adjusted anywhere from 30 to 90 minutes. The timer is set to 60 minutes from the factory.

Tank Temperature Dial (Front Cover)

Located on the front cover of the buffer tank controller's cabinet is a dial designed for the end user to adjust the system's comfort and efficiency levels during the heating season. The tank temperature can be controlled on one of two ways – one with “outdoor reset” and one without (set point). When in the LO, MED, or HI positions, the buffer tank controller utilizes “outdoor reset”, or outdoor temperature data to optimize and determine the water supply target temperature. See the graph below which shows how the outdoor reset function works.

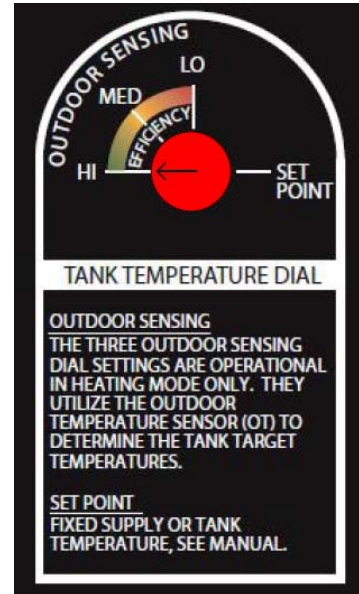
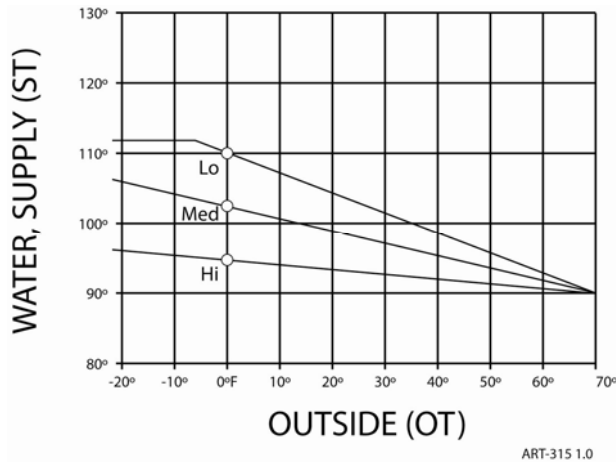

Alternately, when the dial is set to the “SET POINT” position, the controller ignores the “outdoor reset” function and targets the following set points as dictated by the Warm Air Dial:

Set point position (default pos. 3)

- 0 – 85° F
- 1 – 90° F
- 2 – 95° F
- 3 – 100° F
- 4 – 105° F
- 5 – 110° F

NOTE: Due to a feature known as “Maintain Tank Target Less Than OT”, the outdoor sensor must be installed in all applications regardless of front dial setting.

Standby Switch

Located on the front of the Electro Industries Buffer Tank Controller is a two-position switch that can be used to manually disable the system's heat pump and utilize the system's backup heat source only. When in the “up” or STANDBY position, the heat pump will never be active for either heating or cooling purposes.

Enable/Disable Switch

Located on the front of the Electro Industries Buffer Tank Controller is a two-position switch that can be used to turn the controller off, disabling the heat pump and buffer tank controller features. If the controller standby switch is in the “up” position, the system's boiler or furnace will remain active even if the controller is disabled.

On-board Controller Dials

On the right-hand side of the controller board, you will find a series of dials which must be set correctly during the initial set-up. The dial settings are designed to make the buffer tank, and, in turn, the entire HVAC system operate as efficiently as possible. The graphic below will help you identify each dial and understand each dial's function. The dial operations are explained more thoroughly in elsewhere in this manual.

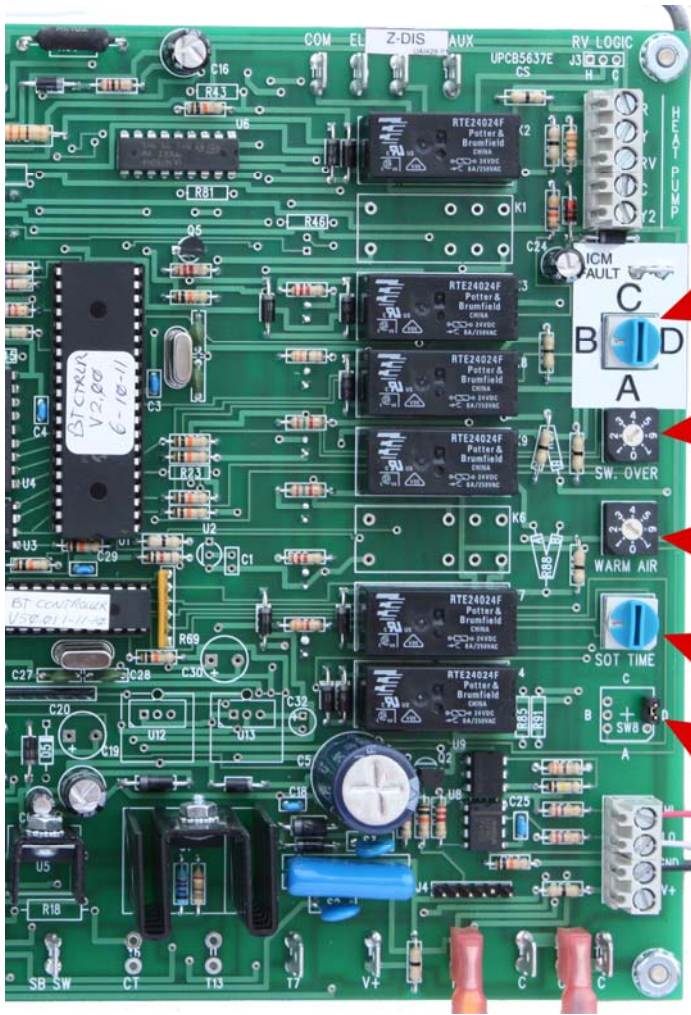

Mode Dial - Selects the operational mode of the system. This is dictated by the type of HVAC components present and active in the system.

Switchover Temp Dial – During the heating season, this dial determines the outdoor temperature at which the heat pump is disabled and the backup heat source takes over. (p.)

Warm Air Dial – When the “Tank Temperature Dial” on the front of the cabinet is in the “Set Point” position, this dial determines the set point temperature. (see below)

Stat Override Timer – This dial starts a timer, which, at the timer expiration, initiates various actions based on Mode and outdoor temperature.

Forced Air Priority Jumper – Removal of this jumper gives priority to the forced air coil over the heating zones if the stat is not satisfied at the conclusion of the pre-set time period. (p.)

Mode Switch

- Mode A – Non-standby mode. The entire heating and chilled water load will be serviced by the heat pump only.
- Mode B – Fossil fuel furnace standby mode. Use mode B when a standby (backup) fossil fuel forced air heat source is present. This is the proper mode if your system will be using a forced air furnace as a backup to take advantage of utility interrupt (off-peak) programs. When the system is in “standby” condition (which can happen because of utility company interrupt or if the outdoor temperature falls below the SW OVER setting), all hydronic zones are non-functional.
- Mode C – Auxiliary boiler standby mode. Use mode C when a gas or electric boiler is present as a standby heat source. The boiler will utilize the buffer tank target temperature. This setting may be used with utility interrupt (off-peak) programs.
- Mode D – Dedicated to Electro Industries’ NorAire[®] air source heat pump boiler system.

Switchover Temperature (SW OVER)

This switch is shipped from the factory with a square “GAS” label. This label should be removed ONLY if a secondary furnace or boiler is present and active in the system and the Mode Switch is set to “B” or “C”. The installer should remove the label and adjust this switch only after reading this manual and understanding the operation of the switch. Select the desired OT (Outdoor Temperature) where the heat pump is to be shut down and the backup furnace is to be utilized. Even though this dial is only utilized when a gas furnace / boiler is in the system, we recommend setting this dial to “0” position (disable) in modes 1 and 4. From the factory, this switch is set to 0 (disable).

0 = Disable	4 = 5° F
1 = -15° F	5 = 10° F
2 = -10° F	6 = 20° F
3 = 0° F	7 = 30° F

Stat Override Timer (SOT)

The intent of the SOT Dial is to take care of very unusual heat/cool conditions or building matching situations, the general sequence relating to OT temperature should take care of proper thermostat cycling without ever reaching SOT timeout (end). Thus, it is recommended the SOT be a high number. The SOT is a “per call” timer, and is reset as soon as the heat or cool call is satisfied.

0 = 30 minutes	2 = 180 minutes
1 = 90 minutes (default)	3 = 270 minutes

Buffer Tank Controller Dial Configurations

Below is a list of different configurations the Buffer Tank Controller system can be adapted to and the matching appropriate Buffer Tank Controller settings. This section is in regards to possible heating source configuration, interfacing and dial selection

Heat pump only

- Mode Dial: A
- SW Over Dial: 0
- SOT Dial: 0=30min 1=90min 2=180min 3=270min

Heat pump with fossil fuel furnace

- Mode Dial: B
- SW Over Dial: 0
- AUX EL: 0
- SOT Dial: 0=30min 1=90min 2=180min 3=270min
- Thermostat type: Conventional 1H/2C

Heat pump with fossil fuel boiler

- Mode Dial: C
- SW Over Dial: 0
- SOT Dial: 0=30min 1=90min 2=180min 3=270min

Undersized heat pump with electric boiler

- Mode Dial: C
- SW Over Dial: 1=-15°F/ 2=-10°F/ 3=0°F/ 4=5°F/ 5=10°F/ 6=20°F/ 7=30°F
- SOT Dial 0=30min 1=90min 2=180min 3=270min

Heat pump with emergency electric boiler

- Mode Dial: C
- SW Over Dial: 0
- SOT Dial: 0=30min/ 1=90min/ 2=180min/ 3=270min

Undersized heat pump with fossil fuel boiler

- Mode Dial: C
- SW Over Dial: 1=-15°F/ 2=-10°F/ 3=0°F/ 4=5°F/ 5=10°F/ 6=20°F/ 7=30°F
- SOT Dial: 0=30min 1=90min 2=180min 3=270min

Undersized heat pump with fossil fuel furnace

- Mode Dial: B
- SW Over Dial: 1=-15°F/ 2=-10°F/ 3=0°F/ 4=5°F/ 5=10°F/ 6=20°F/ 7=30°F
- SOT Dial: 0=30min 1=90min 2=180min 3=270min

Electro Industries' NorAire[®] Heat Pump Boiler

- Mode Dial: D
- All other dials disabled

V2.00 Setup/Programming

Included with this Buffer Tank Controller is the Buffer Tank Controller PC software (CD and cable). The software on the CD allows for the adjustment of many of the functions of the buffer tank controller. Below is a screen shot of all factory defaults, which can be adjust to allow for better system operation for your application. The installer should verify the correct parameters, see the CD HELP file.

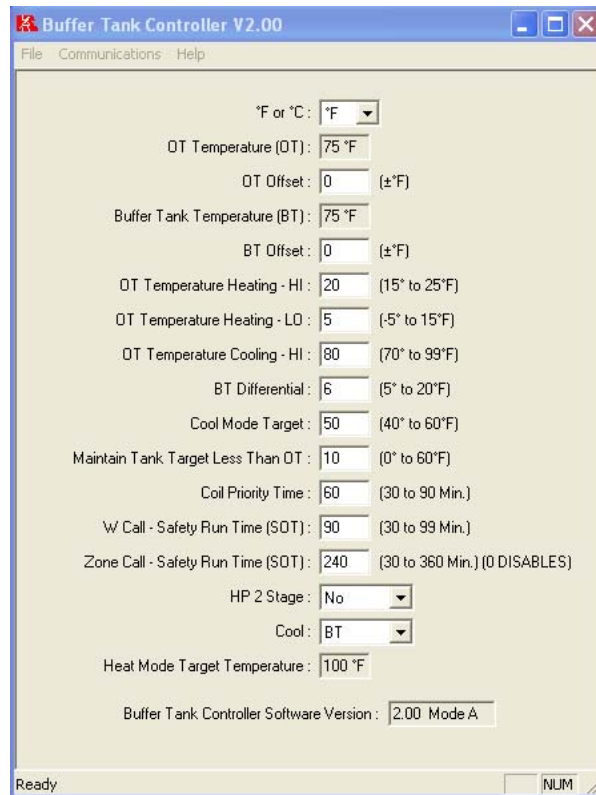

This is the basic information section for the PC CD program. It is not necessary to perform all steps at this time. When the appropriate sections appear in Prestart-up, Start-up, or Troubleshooting revert back to the following.

1. The flat cable connector is plugged into the Logic controller J4 header connector. By looking at the end of the cable female you will notice one pin has a dummy plug. Observing the logic controller board pins you will notice there is one pin missing. This is the keying pin when inserting the cable flat connector.
2. Power must be on the Logic controller board, green LED on.
3. Plug the cable into the PC USB connector.
4. Load in the CD software. The screen should look like the image below.
5. Keyboard – Alt R, monitor field should be filled.
 - a. 2 temperature values
 - b. OT Temperature Heating - HI.
 - c. OT Temperature Heating - LO.
 - d. OT Temperature Cooling - HI.
 - e. BT Differential
 - f. Cool Mode Target.
 - g. Maintain Tank Temperature Less Than OT.
 - h. Coil Priority Time
 - i. W Call – Safety Run Time
 - j. Zone Call – Safety Run Time
 - k. HP 2 stage
 - l. Cool
 - m. Cool
 - n. Heat Mode Target Temperature
 - o. Buffer Tank Controller Software Version
6. Pull down the communication tab and observe the various functions.
 - a. **Write** is required to download any changes. Write downloads the complete screen and all values, whether you change them or not.
 - b. Troubleshooting are convenience functions, see Troubleshooting section.
7. Read HELP file.

Description of software settings:

° F or ° C

This determines whether Fahrenheit or Celsius is used. When changing between these two you will notice any temperature range will also change but any temperature entries made or uploaded from the board will not change, you **must** make sure the entries are within the new range before writing the data back to the board.

Special notes:

Temperature Conversions

Under the "Help" menu there are two conversion selections, ° F to ° C and ° C to ° F. When you select one of these the conversion window opens up. Enter the temperature you desire to convert in the top box. Click on the "Convert" button or press the "Enter" key to see the result in the bottom box. You can enter a decimal number to convert but the result will be rounded to a whole number. Example: If converting ° F to ° C, and 45.6° F is entered, the result will be 8° C (actual value is 7.555555...). Because this window will stay displayed, until you click on the "Exit" button or press the "Esc" key, you can move back and forth between the conversion window and the main window.

Outdoor (OT) and Buffer Tank (BT) Offsets

Enter an offset to be added to or subtracted from the temperature read from the sensor. Example: To enter a 5 degree lower offset, enter: **- 5**.

Outdoor (OT) and Buffer Tank (BT) Temperatures

These are the “read only” values read from the sensor and adjusted with their offsets. They are updated only when a Read Data (Alt+R) is performed.

Note: This can be monitored, along with the Target Temperature, by selecting Monitor Data (Alt+M) from the Communications menu.

OT Temperature Heating - HI

This setting is applicable with two stage heat pumps only. The purpose of this setting is to allow for the heat pump to enter into second stage heating based on outdoor temperature.

System sequence:

- **Outdoor temperature < OT Temperature Heating – HI** = Stage one of the heat pump will be on upon heat call from room thermostat. Stage two heat pump will turn on as a function of timeout (SOT TIME DIAL)
- **Outdoor temperature > OT Temperature Heating – HI** = Stage two heat pump is on upon initial heat demand.

Factory default is 20°F.

OT Temperature Heating - LO

This function is not applicable and should be ignored

OT Temperature Cooling - HI

This setting is applicable with two stage heat pumps only. The purpose of this setting is to allow for the heat pump to enter into second stage cooling based on outdoor temperature.

System sequence:

- **Outdoor temperature < OT Temperature Cooling – HI** = Stage one of the heat pump will be on upon cool call from room thermostat. Stage two heat pump will turn on as a function of timeout (SOT TIME DIAL)
- **Outdoor temperature > OT Temperature Cooling – HI** = Stage two heat pump is on upon initial cool demand.

Factory default is 90°F.

BT Differential

After a heating or cooling demand has been initiated, this temperature is used to develop an operating range at which the actual tank temperature will be kept. The smaller the value the “tighter” the tank temperature will be. The larger the number, the “wider” the operating temperature will be. This must be set with application and heat pump cycling in mind.

Cool Mode Target

After a thermostat cooling call has been initiated, the buffer tank sensor will be referenced and compared to this value. If the tank temperature is greater than or equal to this temperature, the buffer tank controller will signal to the heat pump to begin cooling. If it is less than this value, the tank temperature will be considered ideal for cooling mode operation and the heat pump will not be turned on.

Maintain Tank Target Less Than OT

This function determines the outdoor temperature at which the buffer tank controller will go into a “hot tank” temperature mode. When in heating mode and above this value, the heat pump will not turn on unless there is an active demand for heat from a room thermostat, regardless of buffer tank temperature. When below this outdoor temperature, the buffer tank controller will work to maintain a “hot tank” and maintain tank set point regardless of room thermostat demand.

Coil Priority Time

This timer function allows for a means of providing a forced air priority over all hydronic zones. The value entered is used for the timer which starts with the forced air thermostat. Once this timer expires, the hydronic load is interrupted and the buffer tank energy is dedicated fully in an attempt to satisfy the forced air coil demand. Once the forced air thermostat has been satisfied, the hydronic zones can again receive heat energy from the buffer tank. The timer will begin once again on the next forced air thermostat heat call.

NOTE: The COIL PRIORITY jumper must be removed to activate this timer.
Factory default is 60 minutes

W Call - Safety Run Time (SOT)

During a forced air heat call, there is potential for issues to arise within the heating system that are undetectable via the buffer tank sensors. An example would be an incorrectly calibrated sensor. A timer known as “W Call – Safety Run Time (SOT)” is used to detect such an issue. If this timer expires before the heat call is satisfied, the buffer tank controller will go into an error mode delivering a portion of heat to the space. The HP-Y1 output is also cycled ON/OFF every 15 minutes. HP-Y2 output is turned off.

Factory default is 90 minutes

Zone Call - Safety Run Time (SOT)

During a hydronic zone heat call, there is potential for issues to arise within the heating system that are undetectable via the buffer tank sensors. An example would be an incorrectly calibrated sensor. A timer known as “Zone Call – Safety Run Time (SOT)” is used to detect such an issue. If this timer expires before the heat call is satisfied, the buffer tank controller will go into an error mode delivering a portion of heat to the space. The HP-Y1 output is also cycled ON/OFF every 15 minutes. HP-Y2 output is turned off.

Factory default is 240 minutes

HP 2 Stage

This informs the controller if the system heat pump is the 2-stage type. Select 'YES' or 'NO'.

Cool

This is in regards to the forced air heating and cooling aspect of the HVAC system focusing on the operation of the “coil pump”. The coil pump operates as such:

Upon heating or cooling call from the forced air thermostat:

- If the buffer tank (BT) temperature is greater than or equal to 60°F (16°C) and less than or equal to 80°F (27°C), the coil pump is disabled.
- If the BT temperature is outside of this range the coil pump is enabled.

Heat Mode Target Temperature:

This is the temperature the program is maintaining in the buffer tank when in a heating mode.

- If the front panel 'TANK TEMPERATURE DIAL' switch is in the SET POINT position, the target temperature is determined by the 'WARM AIR' switch setting.
- If the 'TANK TEMPERATURE DIAL' switch is in position HI, MED or LO, the target temperature is the internally calculated value from the actual OT, this switch setting, and the WarmFlo ramp-up curve.

Buffer Tank Controller Software Version

This is the current board software version and the mode the board is in.
The MODE dial switch is read only on a power up.

Front LED Indicator Lights

The LED indicator lights on the front cover allow for fast, easy identification of real time system conditions.

- Green PWR – solid = normal, 24VAC power
 - 1 blink, bad BT sensor
 - 2 blinks, bad OT sensor
- Status
 - On = electric mode
 - Off = standby (SB) or switchover
 - Fast pulsing = Geo unit ICM board fault
 - Slow pulsing = cool mode
 - Fast pulsing with green LED off = mode switch incorrectly set
- HP-STAGE1
 - On = logic board is actively calling for heat pump stage 1
 - Off = no requirement for heat pump stage 1 exists
- HP-STAGE2
 - On = logic board is actively calling for heat pump stage 2
 - Off = no requirement for heat pump stage 2 exists
- Thermostat (forced air only)
 - On = room thermostat actively calling (heating or cooling)
 - Off = no room thermostat demand
- STANDBY
 - On = system is actively calling for backup heating source
 - Off = system is in heat pump mode

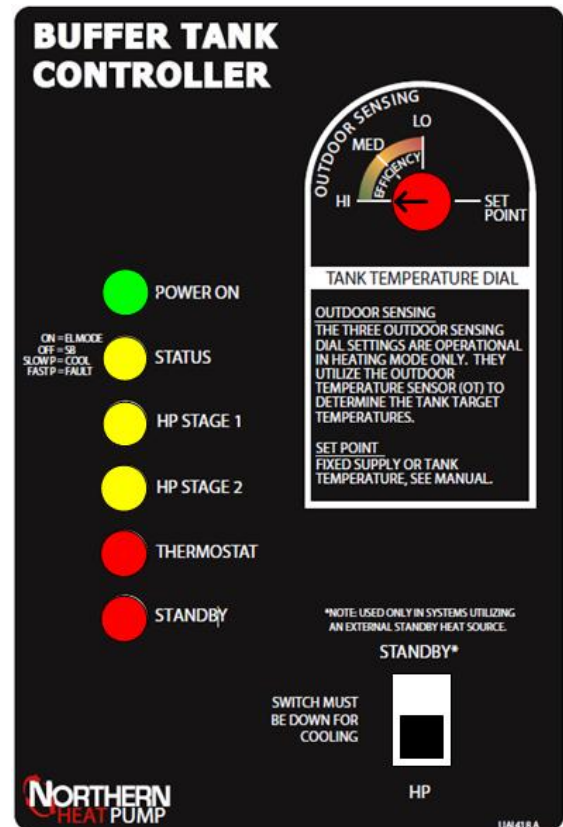

Front panel stand-by/ electric switch (Mode B and C Only) – allows the user to condition the system to select an energy source. This can be used for repair or troubleshooting of the furnace or simply “Power of Choice” selection.

Enable / Disable switch – In some applications, it is advantageous to lockout the heat pump in times when it use will not be required. Example would be cooling season with no cooling load in the HVAC system.

- With the switch in enable, the heat pump is enabled to operate based on room thermostat.
- With the switch in disable, the heat pump is disabled.

Buffer Tank Operation

Buffer Tank Turn-Over

One of the challenges involved in the operation of a hydronic buffer tank system is the inability to quickly and efficiently change the system over from a heating system to a cooling system and vice versa.

During the buffer tank turn-over, the coil pump is disabled if water in the buffer tank is between the temperatures of 60°F and 80°F.

IMPORTANT: It is important for the end user to understand that after the heating season, the first “Y” (cooling) call switches the system to the cooling mode, beginning the process of lowering the temperature of the fluid in the buffer tank. Likewise, the first “W” after a series of “Y” calls sets in motion the sequence for heat or hot water. Since this “buffer tank turn-over” requires a substantial amount of energy, the frequency of this operation should be held to a minimum.

Heating

Hydronic

Whenever a “W” (heat) call is received from a hydronic zone, the corresponding “OUTPUT” lug on the zone controller circuit board is energized with source voltage (see comments under the “Installation and Hookup” section of this manual). When the Tank Temperature Sensor indicates a temperature is not at the desired levels, the system controller sends a compressor on (Y OUT) call to the Geo unit, signaling the geo unit to start and the main pump to turn on.

Forced Air

When the air stat servicing the forced air coil loop sends a “W” call, it starts the forced air coil pump (BT > 80°F) and furnace/air handler blower (F-G). When the coil pump is plumbed as shown on HH120, the buffer tank fluid must be circulated through the geo with the use of the main pump. The Buffer Tank Controller software ensures that whenever the coil pump is required, the main pump is on as well (not applicable in “B” mode).

Chilled Water (cooling)

During the water chilling operation, the zone controller and zone pumps are inactive. When the buffer tank is being chilled, the OT (outdoor temperature) sensor is utilized to determine if a 2-stage heat pump will operate in “stage 1” or “stage 2”. The OT sensor is not utilized to adjust the target tank temperature during chilled water operations. Rather, the temperature inside the tank is maintained at a certain set point. From the factory, this set point is 50°F (Operational differential is 4° F) but can be adjusted anywhere from 40°F to 60°F with the use of a PC computer and the appropriate software. The cooling operation requires a “Y” signal from the thermostat servicing the forced air coil loop. When this happens, the buffer tank controller outputs a “Y” to the heat pump. It also outputs an “O” to the heat pump signaling the heat pump’s reversing valve to reverse refrigerant flow. If the heat pump is a 2-stage unit, first stage cooling (Y1) will be the usual operating condition. The buffer tank system controller will only send a second stage cooling call (Y2) to the heat pump if unusual conditions occur, such as:

1. The outdoor temperature is greater than 90° F
2. The expiration of SOT timeout if the outdoor temperature is less than 90° F
3. During buffer tank heat-to-cool “turnover” if the tank temperature is warmer than 60° F

See the attached charts for a further explanation of how the controller reacts under different operating conditions.

Efficiency Feature Pertaining to an Idle System

Without a room-thermostat initiated call for heat, the Buffer Tank controller will allow the buffer tank temperature to fall below the target temperature if the outdoor temperature is above a designated temperature (See: **Maintain Tank Target Less Than OT**). This can allow for greater system efficiency during moderate outdoor temperatures. The factory-set designated temperature where this feature is allowed is 10° F. However, using the appropriate software (available from Electro Industries) this temperature can be adjusted up or down as desired.

System Pump discussion:

A-Coil Pump and Main Pump: B & C Mode Only

This paragraph relates to the main pump and A-Coil pump relationship during standby mode operation.

In the case of mode B, the standby heat source is a fossil fuel furnace, therefore neither the main pump nor the A-Coil pump are allowed to operate during standby mode operation (no water is being heated).

In the case of Mode C, the standby heat source is an auxiliary boiler, therefore both the A-Coil pump and the A-coil pump will operate if there is a requirement for the A-Coil pump (forced air demand and BT > 80°F). This functionality in mode C allows for proper operation in regards to suggested plumbing shown on HH120.

Hydronic Zone Pumps or Valves: Mode B

The application for mode B is water to water geothermal heat pump and fossil fuel furnace (backup). Therefore when the system is operating in standby (fossil fuel furnace), all zone pumps or valves are disabled due to the fact that no water is actively be heated.

Circulating Zone Pump Exerciser

To reduce the chance of the circulating zone pumps seizing due to long periods of inactivity (summer time), the circulating pumps will run for 30 seconds if they have not been run in the last seven days.

Special Notes in Regards to Modes:

Mode A Special Notes:

Mode A application is designed for heat pump only systems where no other form of system heating exists (fossil fuel furnace or auxiliary boiler). Therefore there is no function as it relates to interruptible rates from the power company (LMC) in the heating mode (no stand-by source). Cooling mode interrupt functions as detailed in this manual.

Additional notes:

- SW OVER dial is not used and should be set to (0).
- All other dials are applicable in this setup and should be set accordingly as per described in the manual

Mode B Special notes:

Mode B application is heat pump in conjunction with a back up or standby *forced air* fossil fuel furnace. Therefore, when in stand-by mode there is no means of heating the space via the hydronic heating. It is assumed in the engineering of this device that forced air would be the predominant means of heating in the space in this application due to no hydronic heating ability in standby mode. Special care must be taken with this concept in design with regards to standby operation.

Example: It must be realized that when the SW OVER dial is “set” in this mode, there will be no hydronic heating below set balance point. The same is true for power company interrupt rates as well as front over ride switch.

Additional Notes:

- All dials are applicable in this setup and should be set accordingly as per described in the manual
- No SOT to fossil fuel exists within this controller

Mode C Special Notes:

Mode C application is heat pump in conjunction with an auxiliary boiler. Therefore when in stand-by mode both hydronic heating and forced air heating is taken care of by the auxiliary boiler, buffer tank and buffer tank controller combination.

In Mode C the auxiliary boiler could be an electric boiler backup (Electro Industries Boiler) or a fossil fuel boiler. This should be noted in applications that include power company interruptible rates. This is because the logic within the Buffer Tank Controller can not distinguish between the two boilers (gas vs. electric) and therefore simply sends out a heat demand signal (W) upon demand from hydronic zones or forced air loop. If it is desired to include an electric boiler in this type of application, the installing contractor must devise a means of controlling both the electric boiler and the Buffer Tank Controller (SPDT relay).

Additional Notes:

- All dials are applicable in this setup and should be set accordingly as per described in the manual
- No SOT to auxiliary boiler exists within this controller

Troubleshooting – Buffer Tank Controller

Sensor Temperature Calibration – both remote sensors are digital electronic and factory calibrated. Normally these do not require field calibration or verification. However, if sensor temperature error is determined, use special PC software disc and PC serial port cable. The PC screen has direct readout of both temperatures, allows a visual determination of the system's internal logic temperature settings, and can be used to offset either temperature sensor for troubleshooting and demonstration purposes. This is especially valuable during summer installation.

SOT bypass – adding a jumper wire between J6 and Common will shorten the SOT time down to 1/30th of the SOT set point. For example. If SOT dial is set to position 0 (30 minutes), the EZGEO control will switch to full output in one minute with the test wire in place.

Bad sensor, safety – if the internal logic detects open sensor wire, incorrectly wired sensor, or some bad sensor transmitted value conditions; the green LED reverts to a pulsing mode. Basically the appropriate sensor is set internally to a 0° value and the WarmFlo main board only allows stage 1 and stage 2 on.

- OT sensor – approximately 1/10 second blip every ½ second
- ST sensor – two, 1/10 second blips every ½ second
- Both bad – ½ second on and ½ second off, alternating

Safety Backup, Defective Buffer Tank Temperature Sensor

Particularly in northern climates, a defective buffer tank temperature sensor (BT) can set in motion a series of events which can result in the heat pump shutting down because pressure faults . To protect the home from a possible freeze-up situation, Electro Industries has designed the Buffer Tank Controller to be capable of detecting a non-operating tank temperature sensor. Should this happen, the Buffer Tank software will initiate the following sequence.

1. With the Mode Dial set to Mode B or Mode C and the system under a heating call, the system will operate in “Standby” condition.
If a cooling call is present, the heat pump is cycled 15 minutes on and 15 minutes off.
2. If the Mode Dial is set to Mode A, the heat pump is cycled 15 minutes on and 15 minutes off in both heating and cooling mode.

Keep in mind that even though the controller logic can detect a non-operating OT sensor, it cannot detect an OT sensor which is returning an incorrect temperature value.

Defective Outdoor Temperature Sensor (OT), declared by software

The Buffer Tank Controller software also has the ability to recognize a faulty OT sensor. Should this occur, the software sets the outdoor temperature to 2° F, the green “POWER” LED will begin to blink, and the software will change target temperature to the set point.

Internal fuses – the zone controller board does contain a 10A fuse for overload protection for zone pumps.

Troubleshooting/Repair Helps

1. This Buffer Tank Controller contains several interference suppression components, but as an electronic logic product, unpredictable and unusual transients or interferences may sometimes cause strange results. If the Buffer Tank Controller is “acting strange”, one immediate step would be power down reset. Simply turn off the voltage source power when the green LED goes out, count to 10, and re-energize power supply.
2. The terminal blocks for control wire hook-up are designed for a wire insertion and screw clamp down. If there is no wire connected and the screw is loose, the screw may not necessarily make a good electrical contact to the inside components. Example – if you are jumpering the thermostat terminals without thermostat wire connection or if you are attempting to measure voltage on the screw head, you may get erroneous or unpredictable results if the screw is not tightened down.
3. Use general heating system logic information and basic understanding of the terminal block wiring functions when measuring voltage to determine proper operation of this module.
4. The outdoor sensor must be located outdoors for this controller to correctly operate. Do not leave the outdoor sensor “hanging in conditioned space” and attempt to run this system

Front panel override switch – if the mode switch is set to “B” and gas furnace is active via Buffer Tank Controller board with a potential heat pump problem, the front panel switch in the up position will transfer the roomstat to the gas furnace. Depending upon the blower configuration, it should follow with the functioning gas furnace, but local HVAC contractor needs to verify.

Front panel override switch – if the mode switch is set to “C” and Auxiliary Boiler is active via Buffer Tank Controller board and a potential heat pump problem is encountered, placing the front panel switch in the “up” position will transfer the roomstat signal to the auxiliary boiler. Depending upon the pump configuration, it should follow with the functioning auxiliary boiler, but local HVAC contractor needs to verify.

Alarm/Fault Active

The status LED and alarm output continue until power-off reset. The Buffer Tank Controller will attempt to maintain room temperature or prevent freeze-up.

- Mode A – by definition, no backup, at each roomstat W cycle, compressor will retry.
- Modes B – with gas furnace standby, forced air roomstat W is transferred to gas furnace operation.
- C – with auxiliary boiler standby, forced air roomstat and hydronic roomstat W is transferred to auxiliary boiler operation.
- Cooling – same as mode A, each thermostat cycle will attempt a compressor.

Note: Do not repeatedly cycle the compressor and cause consecutive faults. This will result in **permanent** compressor damage and perhaps void the product warranty. If the Geo system goes into a fault mode, it has already made three attempts to clear the limit condition, repeated cycling of the roomstat will not do any good, and it will simply cause damage. Call for service.

Backup/freeze-up – the intent of modes B and C with either auxiliary boiler or gas furnace is to prevent building freeze-up. If this Geo system is installed without backup (mode A) there is no secondary means of creating heat.

Correct use of mode selection – by definition modes B and C installation **include** gas furnace or auxiliary boiler module. If the system is setup in either B or C and there is no gas furnace or auxiliary boiler, freeze-up may still occur because the roomstats are assuming a heat source which will bring up the temperature to satisfy the roomstat.

WARNING

WHEN CONFIGURED WITH A GAS FURNACE OR AUXILIARY BOILER (MODES B, or C) IT IS THE USER'S RESPONSIBILITY TO HAVE CIRCUIT BREAKERS TURNED ON, GAS IN THE TANK, GAS VALVES OPEN, AN OPERATIONAL GAS FURNACE, BOILER, ETC. THE BUFFER TANK CONTROLLER CANNOT DETECT “NO GAS IN THE TANK”.

NHP GEO BUFFER TANK SYSTEM

- Zero pressure, open loop.
 - See sheet 7 for Buffer Tank Controller.
- This is designed as an integral part of the system.

WARNING: THESE ARE SUGGESTED AND CONCEPT DRAWINGS. INSTALLER IS RESPONSIBLE FOR ALL EQUIPMENT, ADDITIONAL COMPONENTS, AND DETAILING REQUIRED BY LOCAL CODES.

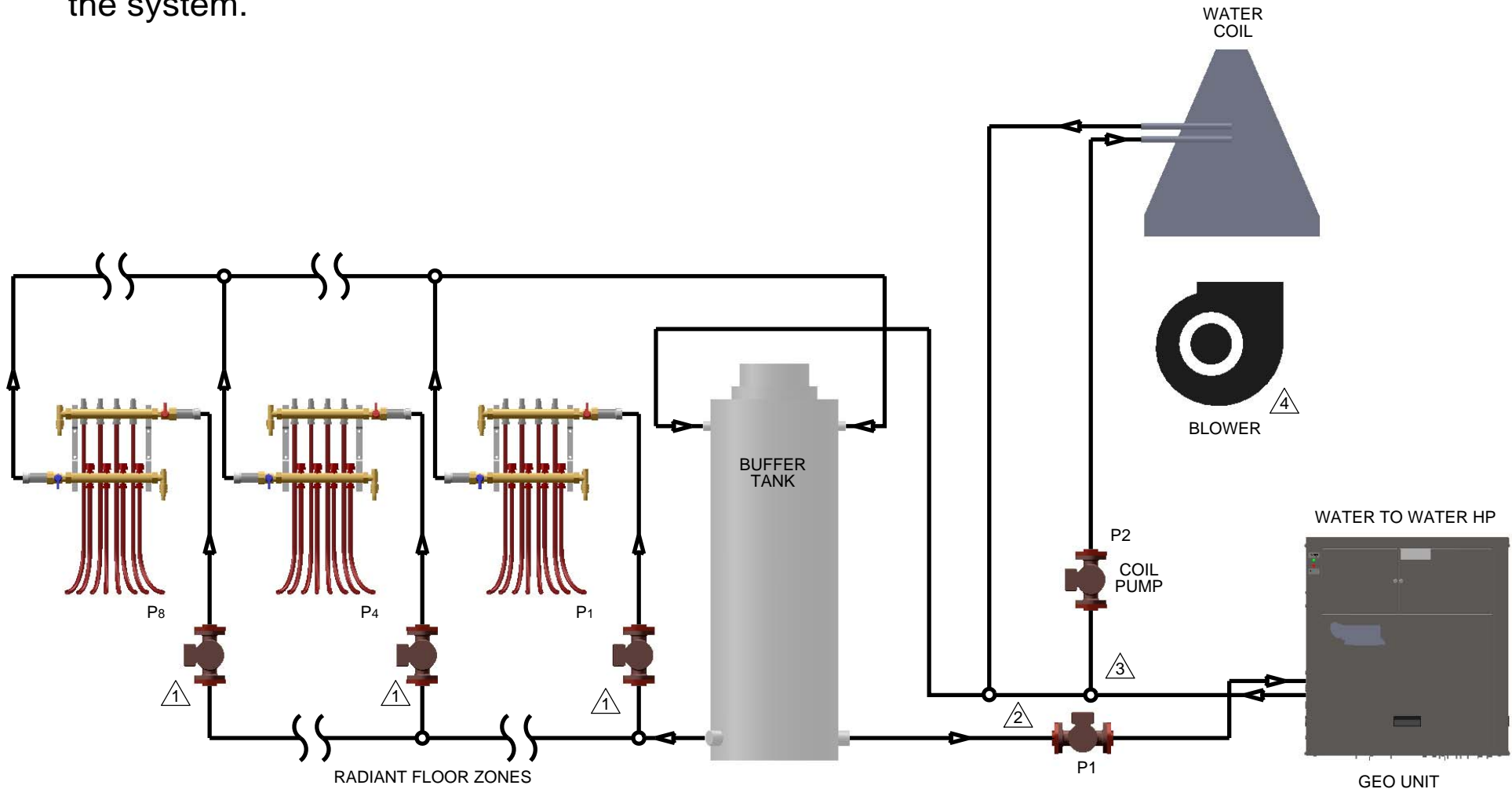

- △ 1 PUMP CHECK VALVES REQUIRED, EXAMPLE GRUNDFOS UPS15-58FC OR TACO 00R-MSF1-1FC OR ELECTRO INDUSTRIES ZONE HEADER, SEE SHEET 5.
- △ 2 CLOSE COUPLED TAP, P2 PUMP MUST ALSO CONTROL P1 PUMP (PART OF HP-BTC).
- △ 3 IF SET-UP, FOR COOLING, ALL PIPING MUST BE INSULATED.
- △ 4 WHEN USING BTC MODE B , THIS CAN BE A GAS FURNACE.

NHP GEO BUFFER TANK SYSTEM

- Pressure tank, closed loop.
 - See sheet 7 for Buffer Tank Controller.
- This is designed as an integral part of the system.

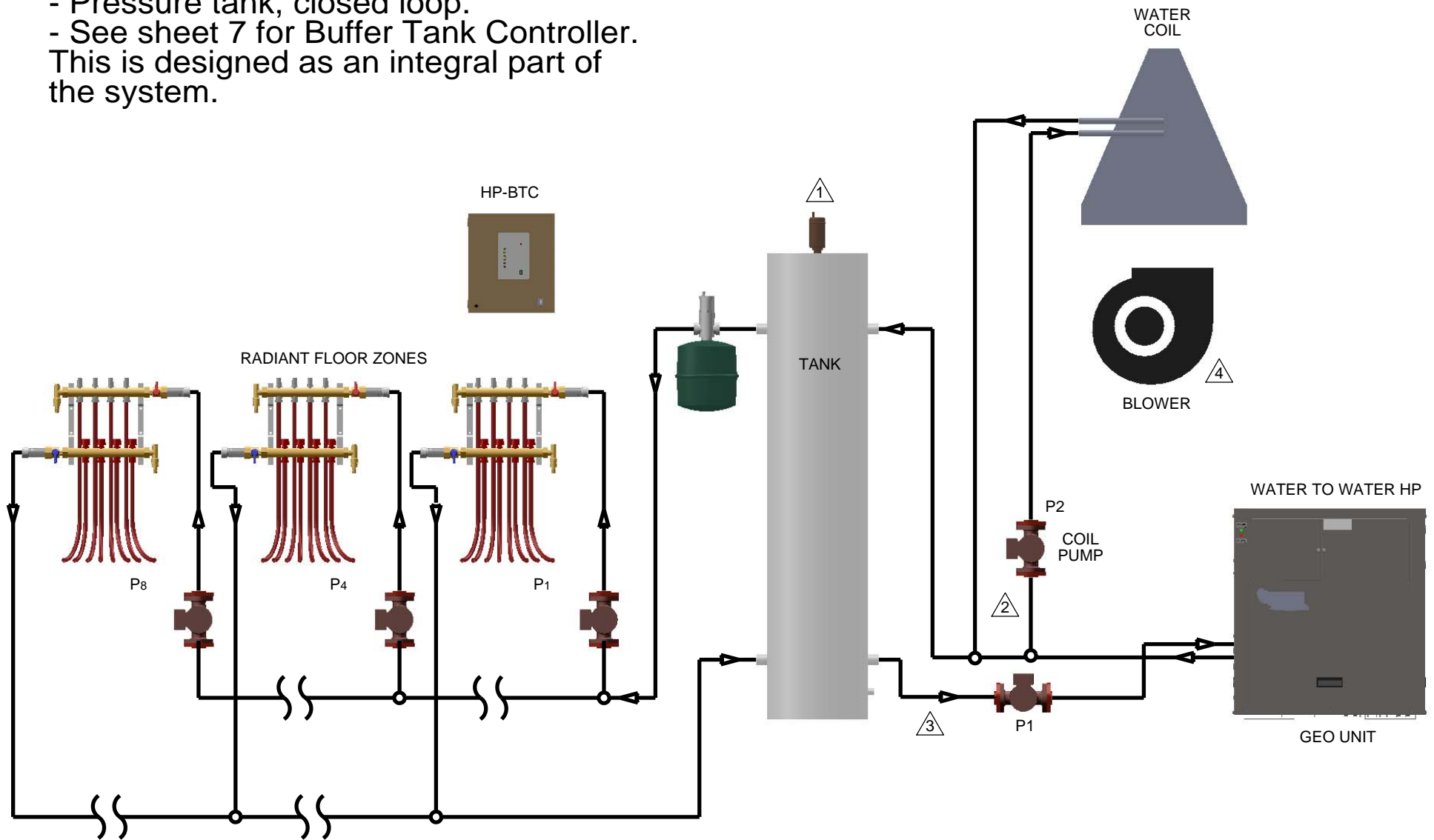

- ① SAFETY RELIEF IS REQUIRED.
- ② CLOSE COUPLED TAP, P2 PUMP MUST ALSO CONTROL P1 PUMP (PART OF HP-BTC).
- ③ IF SET-UP, FOR COOLING, ALL PIPING MUST BE INSULATED.
- ④ WHEN USING BTC MODE B , THIS CAN BE A GAS FURNACE.

NHP GEO BUFFER TANK SYSTEM

- Pressure tank, closed loop.
- Zone valve or manifold actuators.
- HP-BTC controller must be converted to 24V output, see sheet 7.

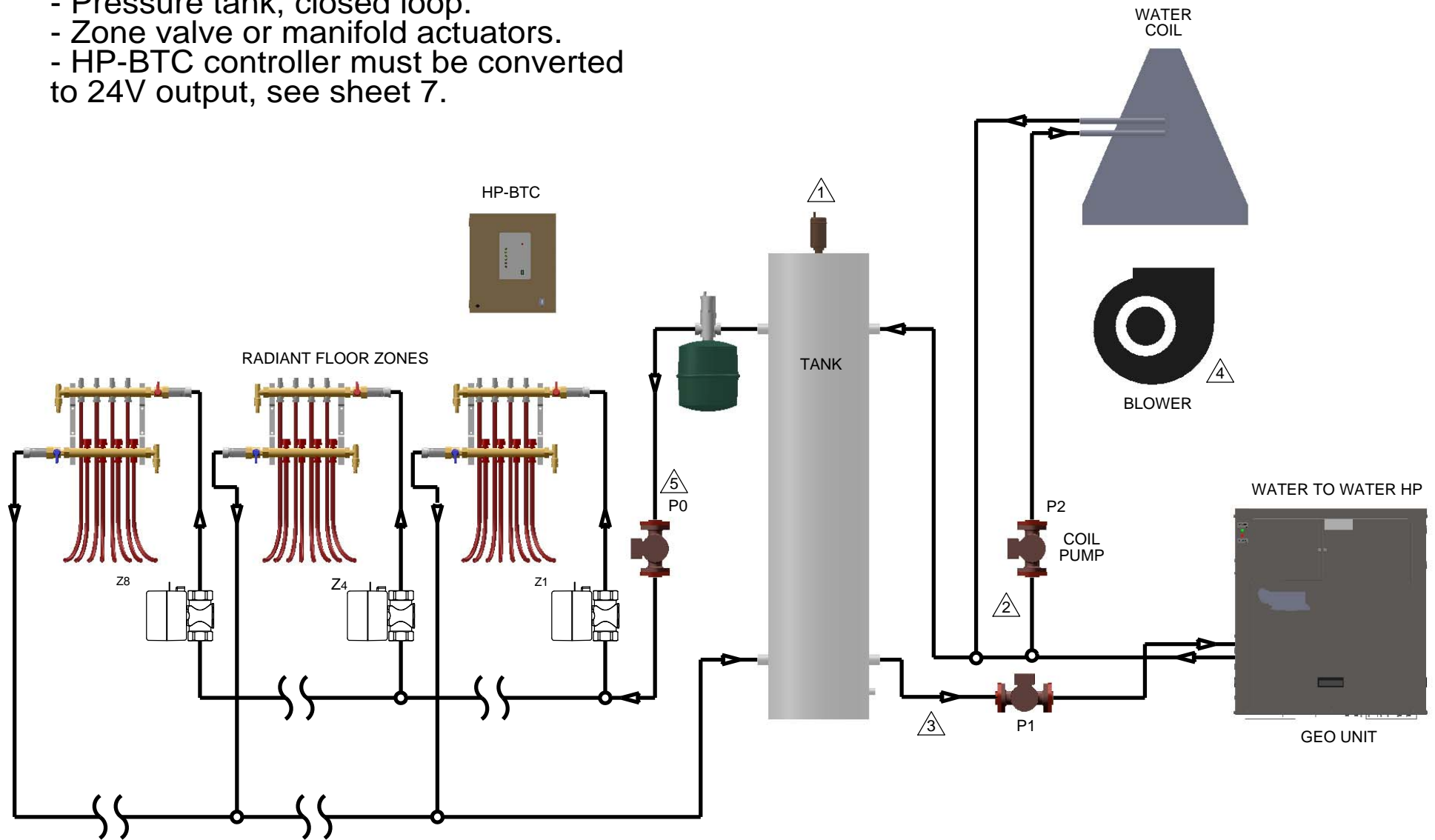

- ① SAFETY RELIEF IS REQUIRED.
- ② CLOSE COUPLED TAP, P2 PUMP MUST ALSO CONTROL P1 PUMP (PART OF HP-BTC).
- ③ IF SET-UP, FOR COOLING, ALL PIPING MUST BE INSULATED.
- ④ WHEN USING BTC MODE B , THIS CAN BE A GAS FURNACE.
- ⑤ P0 IS CONTROLLED BY ZONE BOARD. W-OUT AND POWER RELAY.

NHP GEO BUFFER TANK SYSTEM

- Pressure tank, closed loop.
- Manifold actuators.
- HP-BTC controller must be converted to 24V output, see sheet 7.

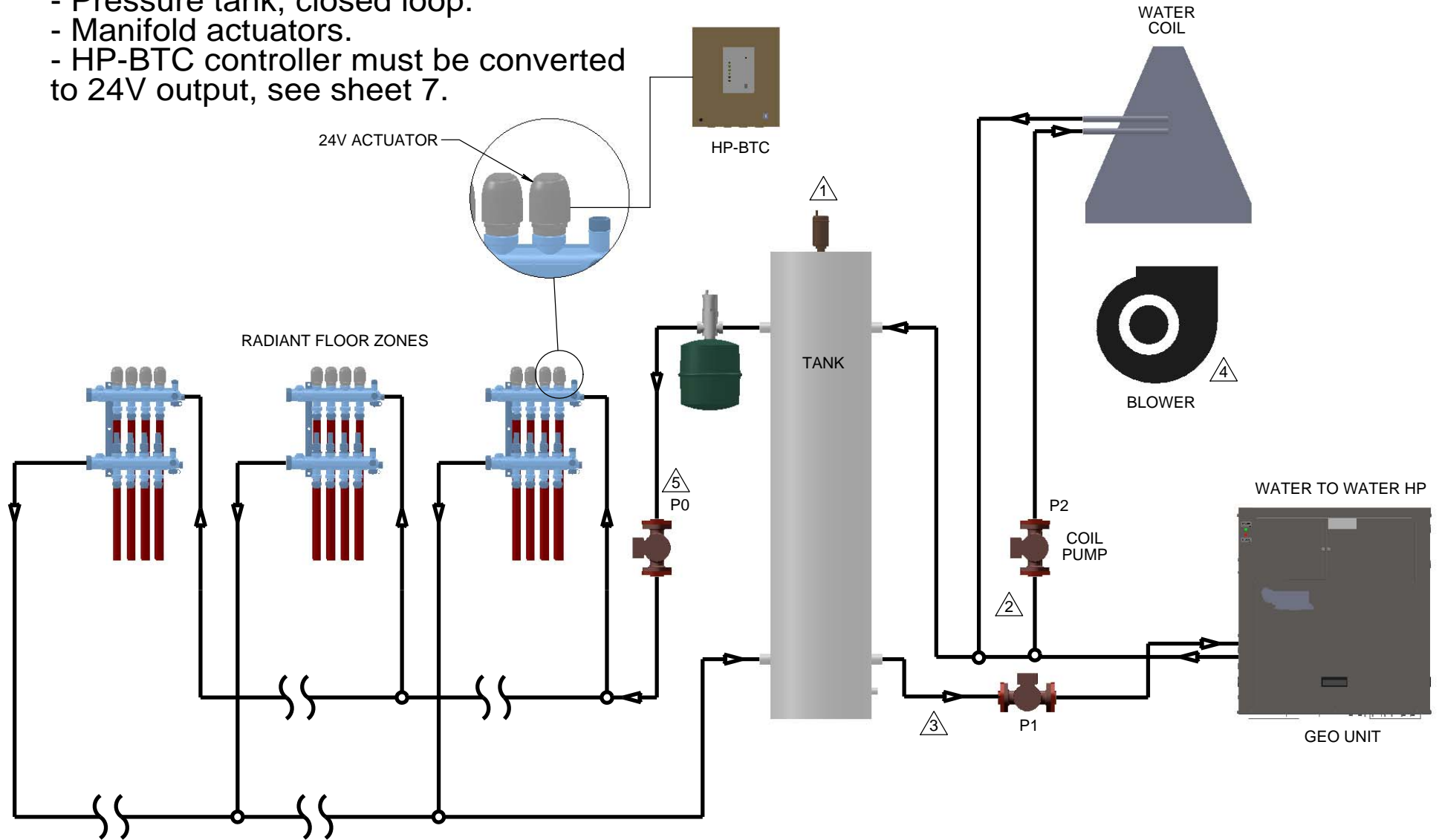

- ① SAFETY RELIEF IS REQUIRED.
- ② CLOSE COUPLED TAP, P2 PUMP MUST ALSO CONTROL P1 PUMP (PART OF HP-BTC).
- ③ IF SET-UP, FOR COOLING, ALL PIPING MUST BE INSULATED.
- ④ WHEN USING BTC MODE B , THIS CAN BE A GAS FURNACE.
- ⑤ P0 IS CONTROLLED BY ZONE BOARD. W-OUT AND POWER RELAY.

NHP GEO BUFFER TANK SYSTEM

- Pressure tank, closed loop.
- Buffer Tank Controller (V3.***) has 2 tank option.
- Back-up gas or EB boiler can be added, as shown.

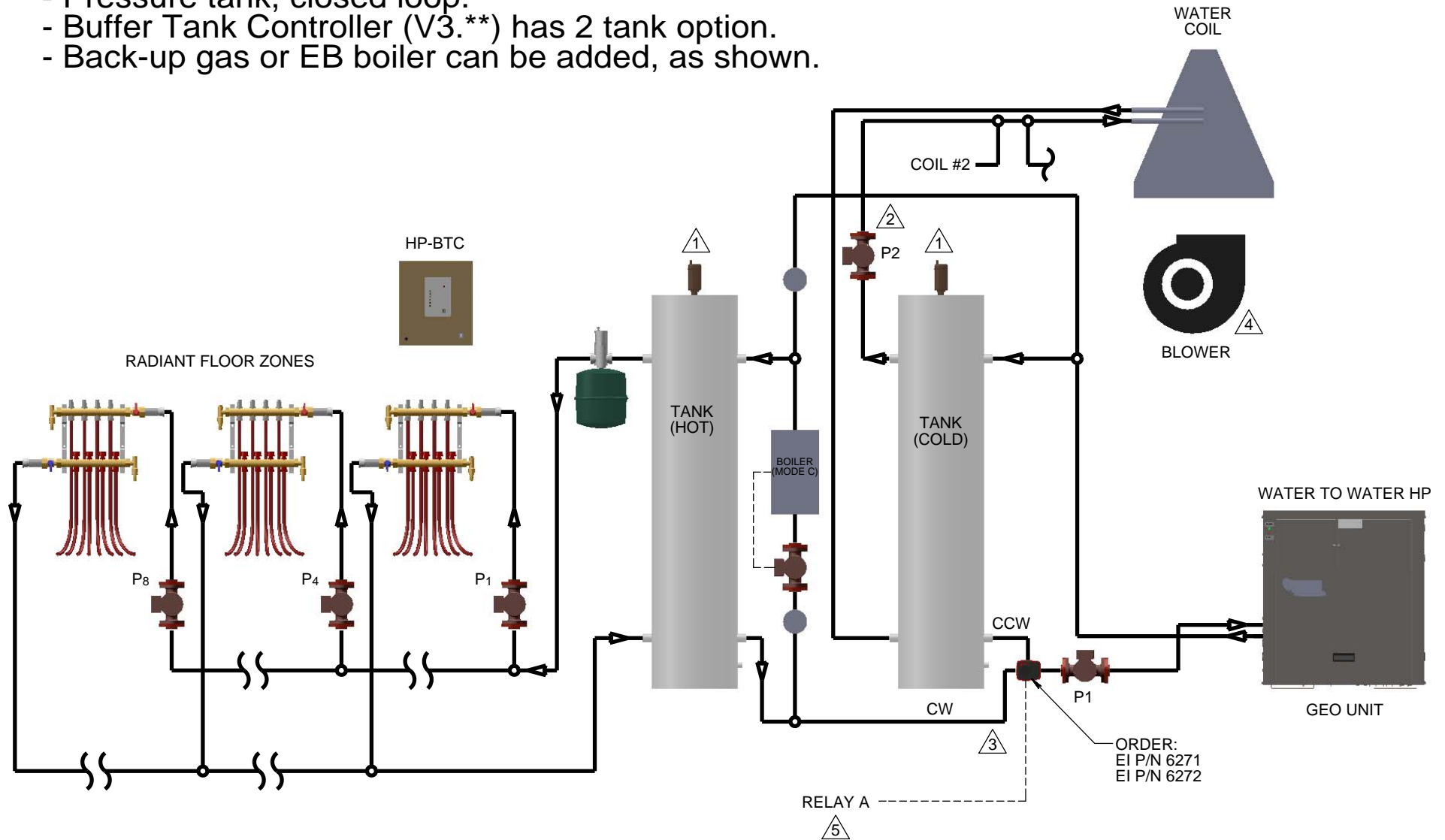

- ① SAFETY RELIEF IS REQUIRED.
- ② CLOSE COUPLED TAP, P2 PUMP MUST ALSO CONTROL P1 PUMP (PART OF HP-BTC).
- ③ IF SET-UP, FOR COOLING, ALL PIPING MUST BE INSULATED.
- ④ WHEN USING BTC MODE B , THIS CAN BE A GAS FURNACE.
- ⑤ CONTROLLED BY HP-BTC OR HP-BTC-24 (V3.**)

BUFFER TANK SYSTEM

- Add auxiliary boiler option.
 - Mode C - Gas boiler or EB-MS-**
- As zero pressure, must have check valves at pump inlet as shown.

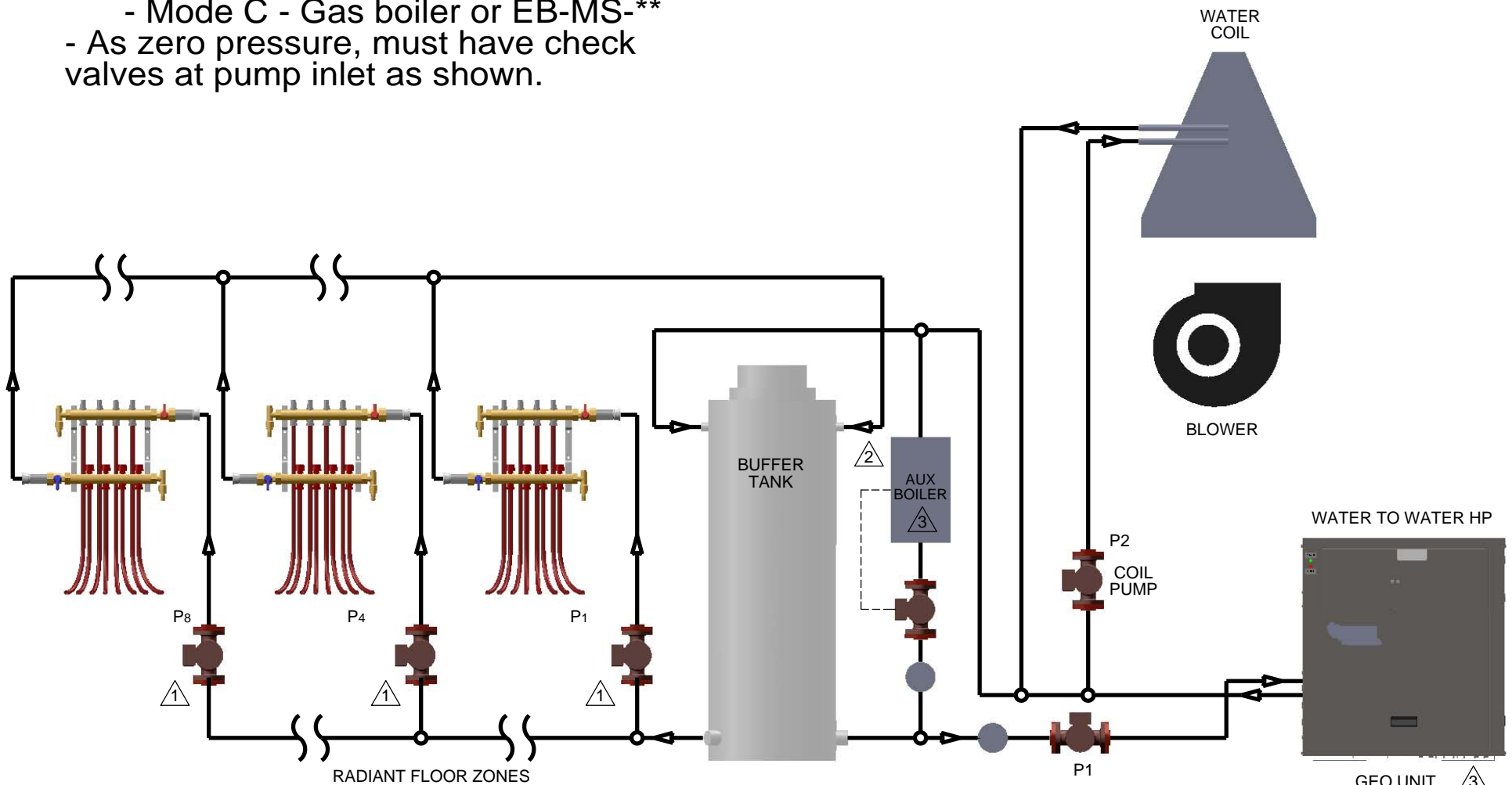

- ① PUMP CHECK VALVES REQUIRED, EXAMPLE GRUNDPHOS UPS15-58FC OR TACO 00R-MSF1-1FC.
- ② STAND-BY OR BACK-UP AUXILIARY BOILER. BTC MODE C OR D PROVIDES WIRING AND CONTROL.
- ③ STAINLESS STEEL OR EQUIVILANT VESSEL/PIPING.

BUFFER TANK PRODUCT

- Zero pressure

MODEL	DIAMETER "D"	GALLONS	ZONE PORTS
BT-030-N	13"	30	1
BT-040-N	17"	40	2
BT-080-N	22"	80	2

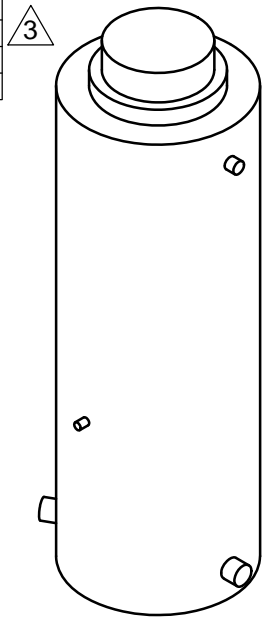
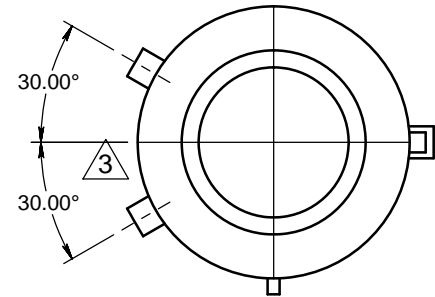

2X 1 1/4" STAINLESS COUPLER

ZONE CAPABILITIES		
ZONES	BT	BASIC MANIFOLD
2	30	1
4	30	2
4	40	2
6	40	3
4	80	2
6	80	3
8	80	4

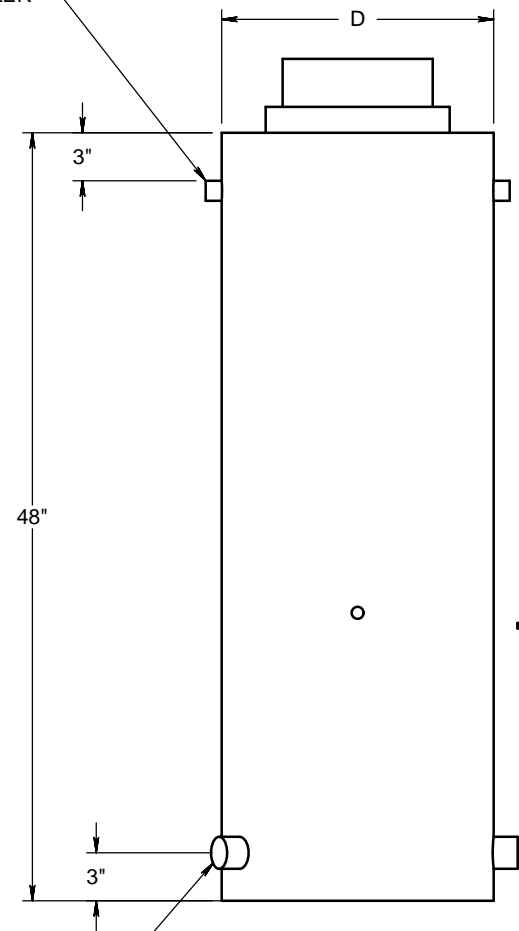

BT-OUT1-100
ZONE HEADER, SINGLE

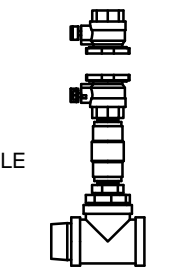

BT-OUT2-100
ZONE HEADER, DUAL

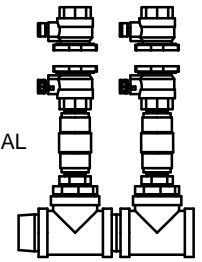

3X 2" STAINLESS NIPPLE



BTPipe
AUXILIARY BOILER CONNECTION



HP PIPING/PUMP FLANGE

NOTES:

- ① SUPPLIED WITH TANK.
- ② ALL HEADERS INCLUDE CHECK VALVE.
- ③ 80 GAL. SHOWN. 30 GAL. HAS A SINGLE ZONE CONNECTION ON THE LEFT SIDE.

BUFFER TANK CONTROLLER (HP-BTC)

ZONE PUMP (OR VALVES) 1-8 ZONES

- FACTORY SET-UP FOR 120V PUMPS.
- IF ALL 240V PUMPS, L2 CAN BE WIRED TO "NEUTRAL", BUT TRANSFORMER WIRE MUST BE CHANGED.
- IF ZONE VALVES (SHEET 3) FIELD CONVERT TO 24V OUTPUT.

1. REMOVE ZONE BOARD BLACK AND WHITE WIRES FROM SOURCE T.B.
2. ADD 1/4" PUSH-ON TO THESE WIRES AND CONNECT AT LOWER LEFT "24VAC" AND "C" TABS.
3. INSTALLERS RESPONSIBILITY TO DETERMINE VA AND REPLACE (EXTERNAL) TRANSFORMER AS REQUIRED.

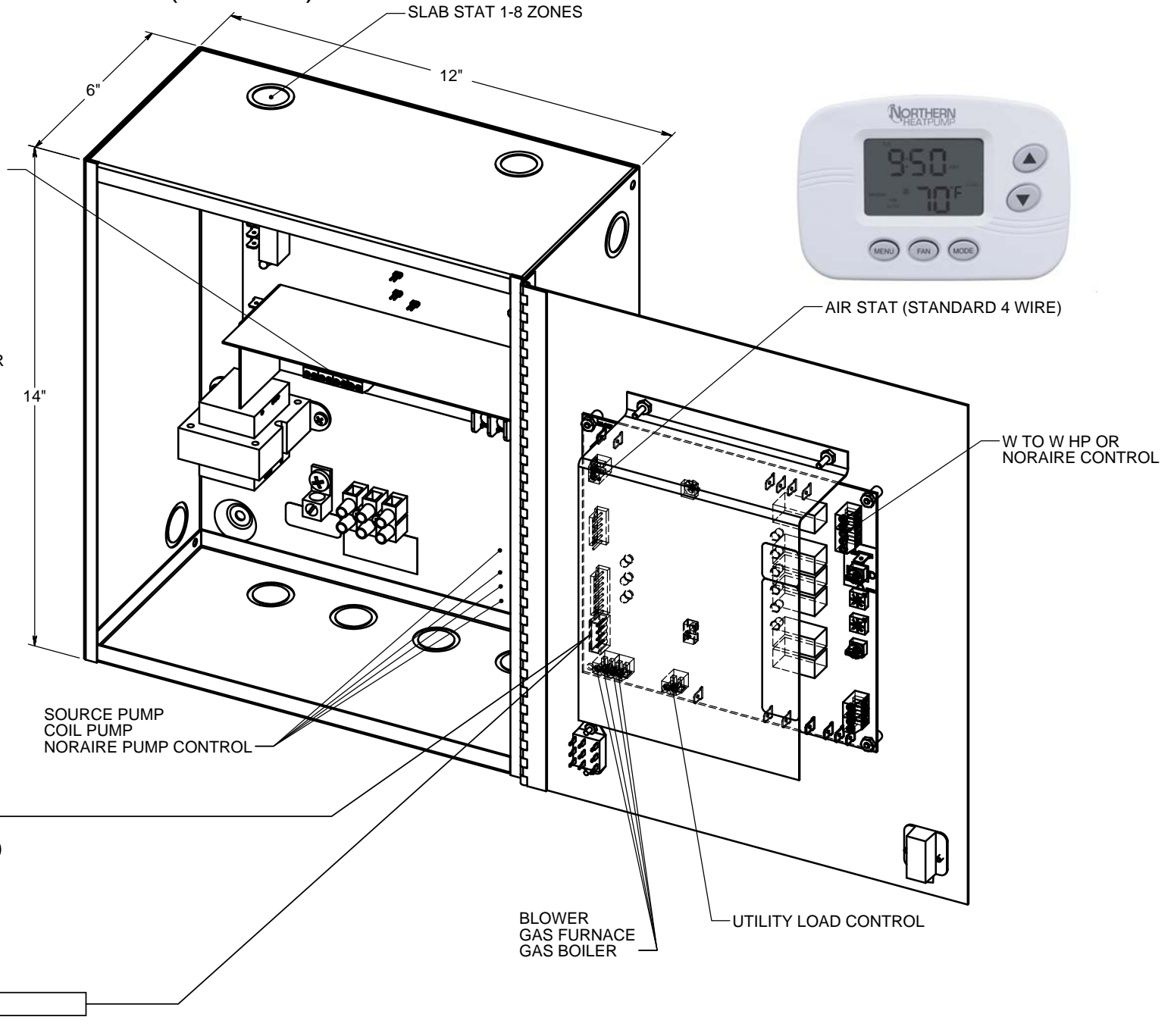

HP-BTC GEO PIPING AND GEO LOAD PUMP WIRING

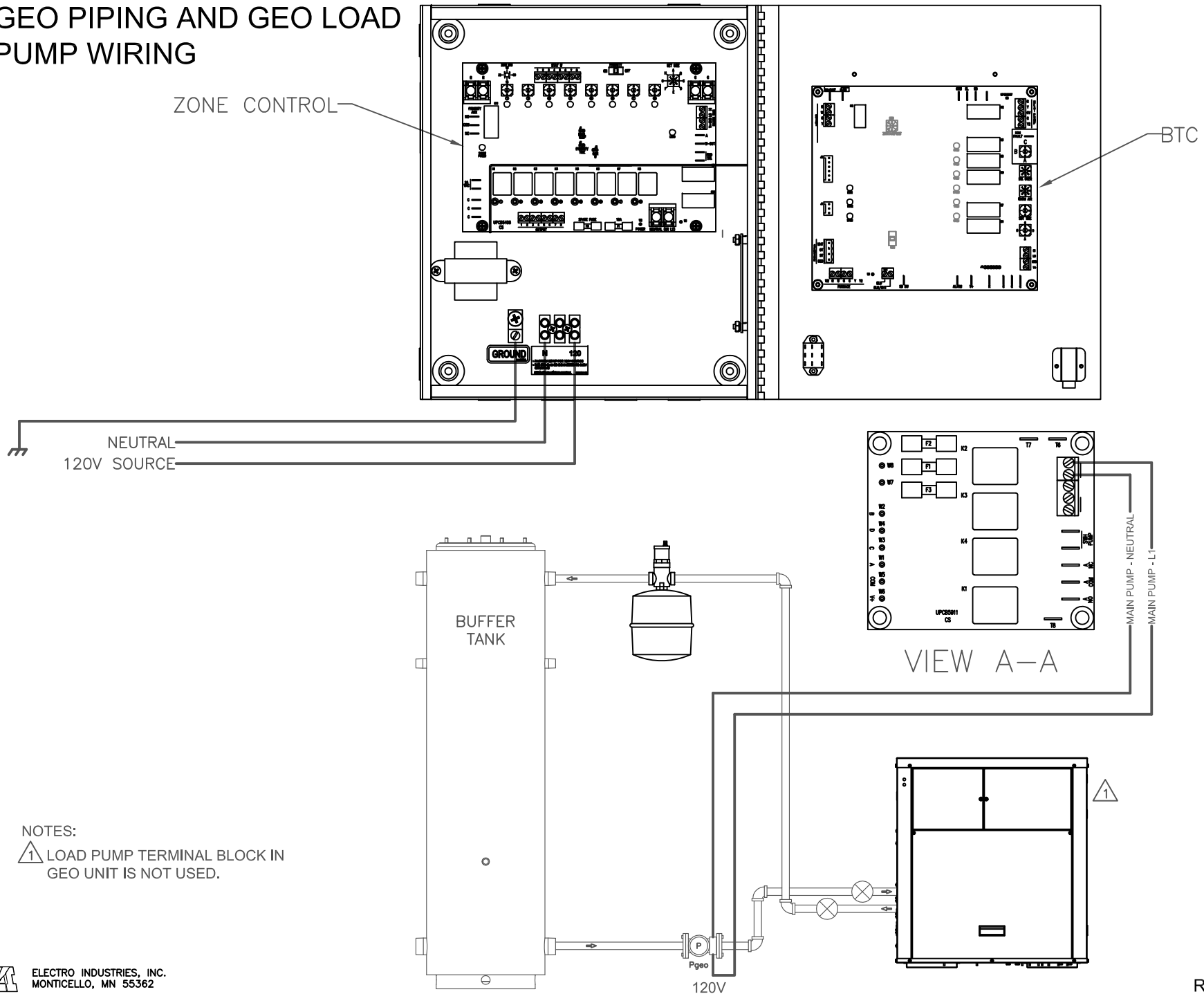

NOTES:
 1 LOAD PUMP TERMINAL BLOCK IN
 GEO UNIT IS NOT USED.

HP-BTC FORCED AIR COIL, AIR HANDLER (IF GAS FURNACE SET TO MODE B & CONNECT GAS W TO BTC F-W)

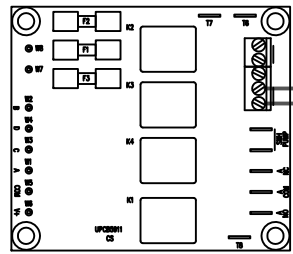

VIEW A-A

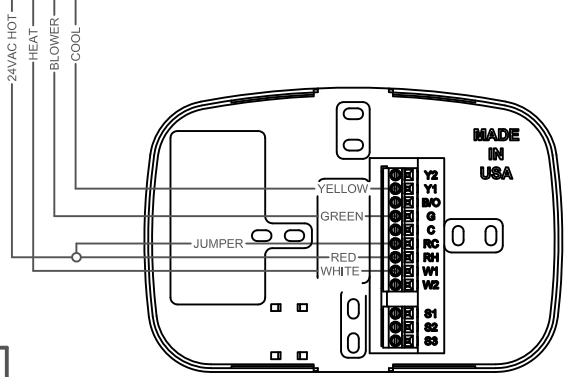
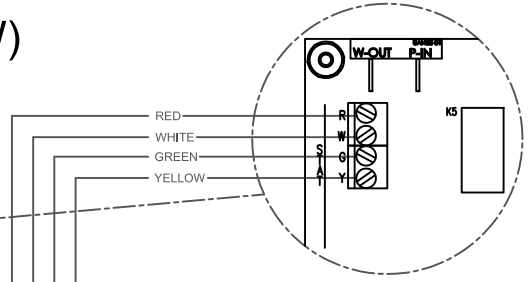
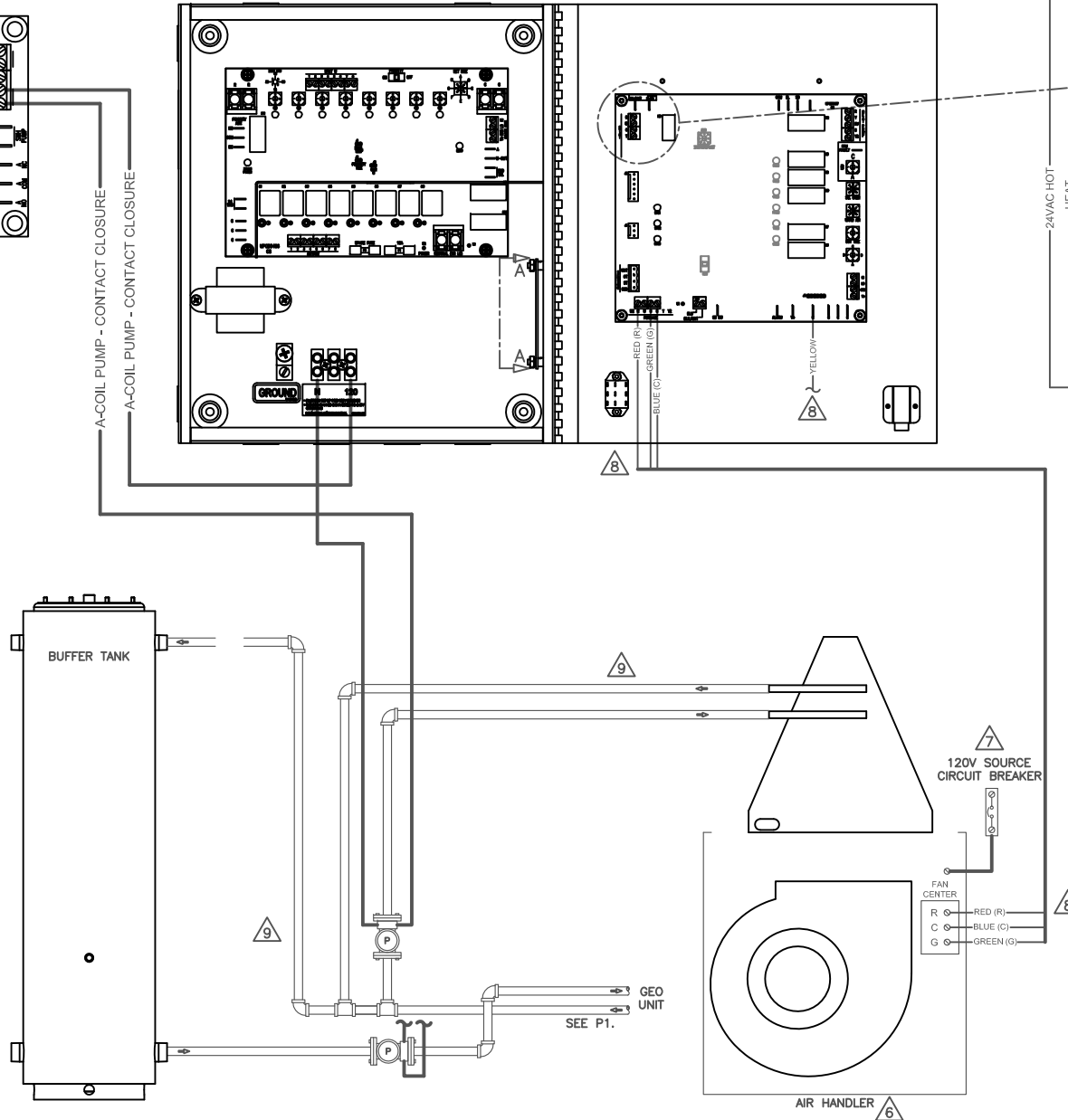



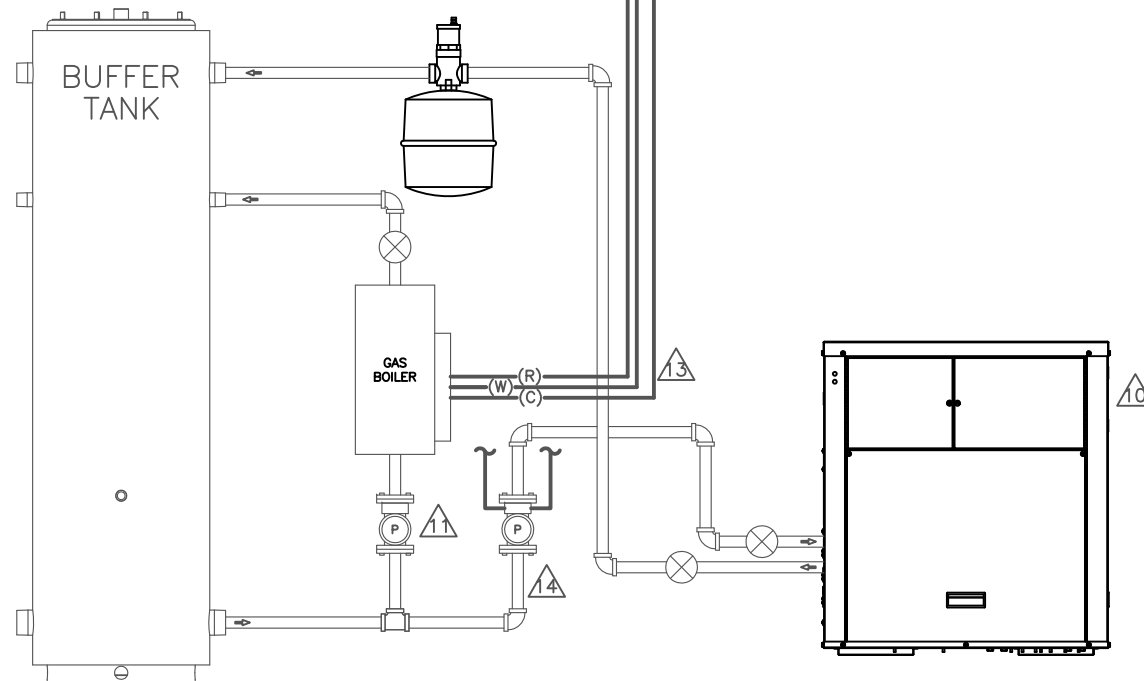
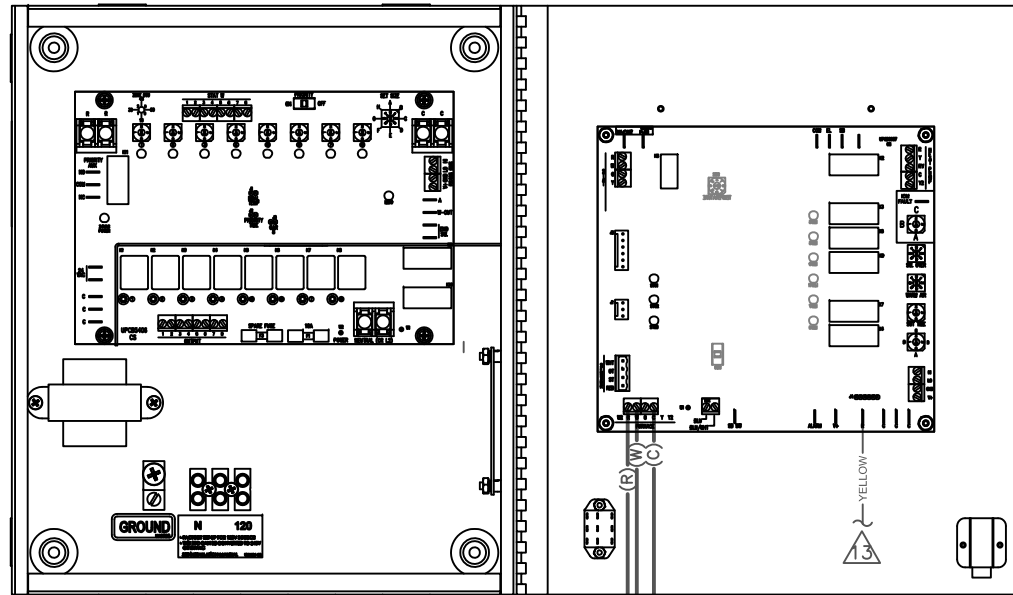

EI P/N #5021

- NOTES:
- ⚠️ 6 FILTER NOT SHOWN.
 - ⚠️ 7 AIR HANDLER SHOWN WITH ITS OWN 120V POWER AND 24V TRANSFORMER.
 - ⚠️ 8 WHEN POWERING BTC BOARD FROM AH OR GAS TRANSFORMER:
 - CONNECT R TO R.
 - MUST PULL YELLOW 24VAC WIRE.
 - Y IS AVAILABLE FOR BLOWER SPEED-UP.
 - ⚠️ 9 COOLING - ALL PIPES MUST BE INSULATED.

HP-BTC STAND-BY BOILER MODE C



NOTES:

-  LOAD PUMP TERMINAL BLOCK IN GEO UNIT IS NOT USED.
-  PUMP CONTROLLED BY GAS BOILER.
-  WHEN POWERING BTC BOARD FROM AH OR GAS TRANSFORMER:
- CONNECT R TO R.
- MUST PULL YELLOW 24VAC WIRE.
-  IF ZERO PRESSURE TANK, CHECK VALVES REQUIRED.

HP-BTC-24 GEO PIPING AND GEO LOAD PUMP WIRING

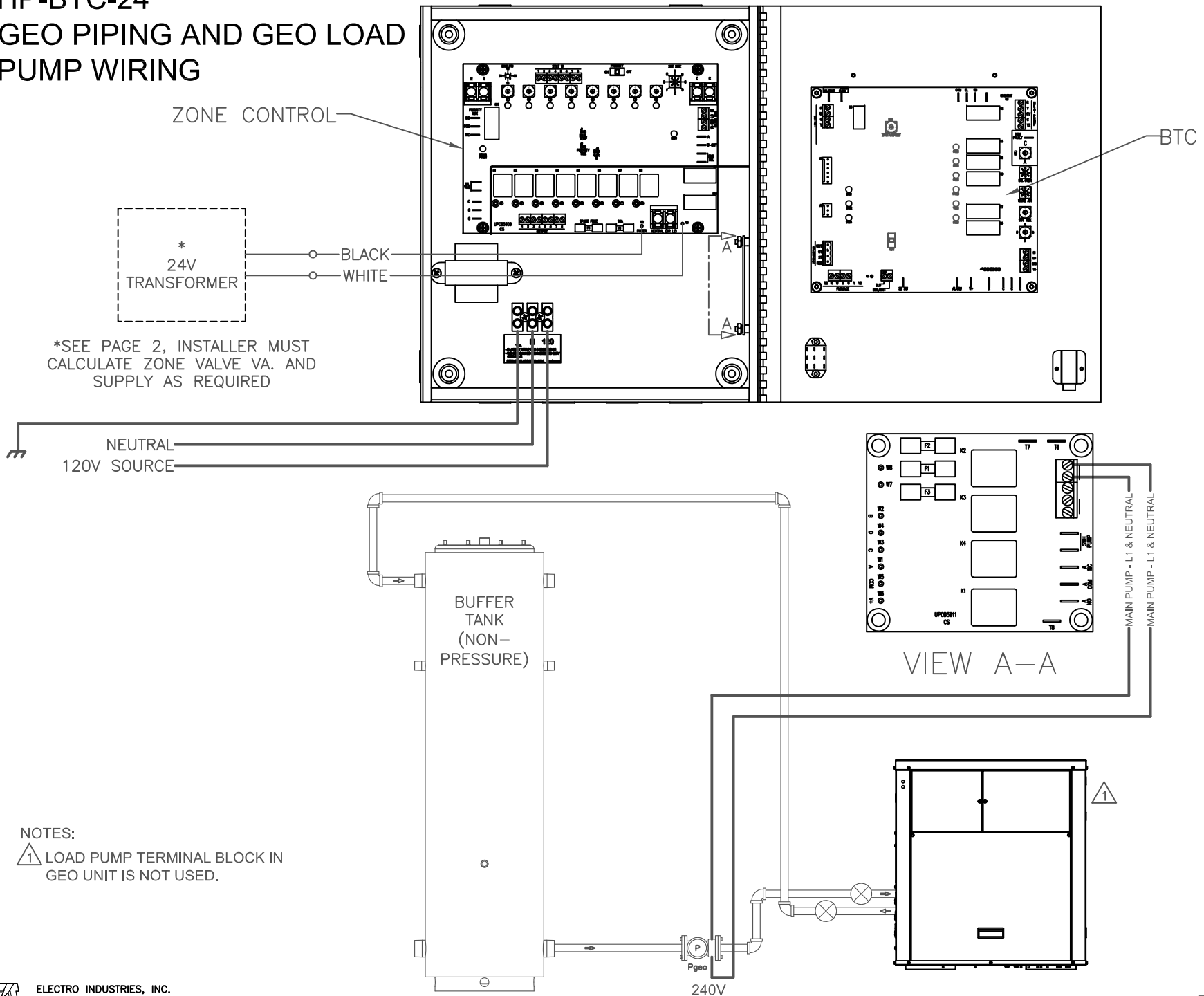

Electro Industries, Inc. Residential Limited Product Warranty

Effective November 1, 2009

Electro Industries, Inc. warrants to the original owner, at the original installation site, for a period of two (2) years from date of original purchase, that the product and product parts manufactured by Electro Industries, Inc. are free from manufacturing defects in materials and workmanship, when used under normal conditions and when such product has not been modified or changed in any manner after leaving the plant of Electro Industries, Inc. If any product or product parts manufactured by Electro Industries, Inc. are found to have manufacturing defects in materials or workmanship, such will be repaired or replaced by Electro Industries, Inc. Electro Industries, Inc., shall have the opportunity to directly, or through its authorized representative, examine and inspect the alleged defective product or product parts. Electro Industries, Inc. may request that the materials be returned to Electro Industries, Inc. at owner's expense for factory inspection. The determination as to whether product or product parts shall be repaired, or in the alternative, replaced, shall be made by Electro Industries, Inc. or its authorized representative.

Electro Industries, Inc. will cover labor costs according to the Repair / Replacement Labor Allowance Schedule for a period of ninety (90) days from the date of original purchase, to the original owner, at the original installation site. The Repair / Replacement Labor Allowance is designed to reduce the cost of repairs. This Repair / Replacement Labor Allowance may not cover the entire labor fee charged by your dealer / contractor.

TWENTY YEAR (20) LIMITED WARRANTY ON BOILER ELEMENTS AND VESSELS

Electro Industries, Inc. warrants that the boiler elements and vessels of its products are free from defects in materials and workmanship through the twentieth year following date of original purchase. If any boiler elements or vessels are found to have a manufacturing defect in materials or workmanship, Electro Industries, Inc. will replace them.

TWENTY YEAR (20) LIMITED WARRANTY ON SPIN FIN ELEMENTS

Electro Industries, Inc. warrants that the spin fin elements of its products are free from defects in materials and workmanship through the twentieth year following date of original purchase. If any spin fin elements are found to have a manufacturing defect in materials or workmanship, Electro Industries, Inc. will replace them.

FIVE YEAR (5) LIMITED WARRANTY ON OPEN WIRE ELEMENTS

Electro Industries, Inc. warrants that the open wire elements of its products are free from defects in materials and workmanship through the fifth year following date of original purchase. If any open wire elements are found to have a manufacturing defect in materials or workmanship, Electro Industries, Inc. will replace them.



ELECTRO INDUSTRIES, INC.

2150 West River Street, PO Box 538, Monticello, MN 55362
763.295.4138 • 800.922.4138 • fax 763.295.4434
sales@electromn.com • www.electromn.com

CONDITIONS AND LIMITATIONS:

1. This warranty is limited to residential, single family dwelling installations only. Any commercial or multi-unit dwelling installations fall under the Electro Industries Commercial Limited Product Warranty.
2. Electro Industries, Inc. shall not be liable for performance related issues resulting from improper installation, improper sizing, improper duct or distribution system, or any other installation deficiencies.
3. If at the time of a request for service the original owner cannot provide an original sales receipt or a warranty card registration then the warranty period for the product will have deemed to begin the date the product is shipped from the factory and **NOT** the date of original purchase.
4. The product must have been sold and installed by a licensed electrician, plumbing, or heating contractor.
5. The application and installation of the product must be in compliance with Electro Industries, Inc. specifications, as stated in the installation and instruction manual, and all state, provincial and federal codes and statutes. If not, the warranty will be null and void.
6. The purchaser shall have maintained the product in accordance with the manual that accompanies the unit. Annually, a qualified and licensed contractor must inspect the product to assure it is in proper working condition.
7. All related heating components must be maintained in good operating condition.
8. All lines must be checked to confirm that all condensation drains properly from the unit.
9. Replacement of a product or product part under this limited warranty does not extend the warranty term or period.
10. Replacement product parts are warranted to be free from defects in material and workmanship for ninety (90) days from the date of installation. All exclusions, conditions, and limitations expressed in this warranty apply.
11. Before warranty claims will be honored, Electro Industries, Inc. shall have the opportunity to directly, or through its authorized representative, examine and inspect the alleged defective product or product parts. Remedies under this warranty are limited to repairing or replacing alleged defective product or product parts. The decision whether to repair or, in the alternative, replace products or product parts shall be made by Electro Industries, Inc. or its authorized representative.

THIS WARRANTY DOES NOT COVER:

1. Costs for labor for diagnosis, removal or reinstallation of an alleged defective product or product part, transportation to Electro Industries, Inc., and any other materials necessary to perform the exchange, except as stated in this warranty. Replacement material will be invoiced to the distributor in the usual manner and will be subject to adjustment upon verification of defect.
2. Any product or product part that has been damaged as a result of being improperly serviced or operated, including, but not limited to, the following: operated during construction phase, with insufficient water or air flow; allowed to freeze; subjected to flood conditions; subjected to improper voltages or power supplies; operated with air flow or water conditions and/or fuels or additives which cause unusual deposits or corrosion in or on the product; chemical or galvanic erosion; improper maintenance or subject to any other abuse or negligence.
3. Any product or product part that has been damaged as a result of natural disasters, including, but not limited to, lightning, fire, earthquake, hurricanes, tornadoes or floods.
4. Any product or product part that has been damaged as a result of shipment or handling by the freight carrier. It is the receiver's responsibility to claim and process freight damage with the carrier.
5. Any product or product part that has been defaced, abused or suffered unusual wear and tear as determined by Electro Industries, Inc. or its authorized representative.
6. Workmanship of any installer of the product or product part. This warranty does not assume any liability of any nature for unsatisfactory performance caused by improper installation.
7. Transportation charges for any replacement product, product part or component, service calls, normal maintenance; replacement of fuses, filters, refrigerant, etc.

THESE WARRANTIES DO NOT EXTEND TO ANYONE EXCEPT THE ORIGINAL PURCHASER AT RETAIL AND ONLY WHEN THE PRODUCT IS IN THE ORIGINAL INSTALLATION SITE. THE REMEDIES SET FORTH HEREIN ARE EXCLUSIVE.

ALL IMPLIED WARRANTIES, INCLUDING WARRANTIES OF MERCHANTABILITY AND FITNESS FOR A PARTICULAR PURPOSE, ARE HEREBY DISCLAIMED WITH RESPECT TO ALL PURCHASERS OR OWNERS. ELECTRO INDUSTRIES, INC. IS NOT BOUND BY PROMISES MADE BY OTHERS BEYOND THE TERMS OF THESE WARRANTIES. FAILURE TO RETURN THE WARRANTY CARD SHALL HAVE NO EFFECT ON THE DISCLAIMER OF THESE IMPLIED WARRANTIES.

ALL EXPRESS WARRANTIES SHALL BE LIMITED TO THE DURATION OF THIS EXPRESS LIMITED WARRANTIES SET FORTH HEREIN AND EXCLUDE ANY LIABILITY FOR CONSEQUENTIAL OR INCIDENTAL DAMAGES RESULTING FROM THE BREACH THEREOF. SOME STATES OR PROVINCES DO NOT ALLOW THE EXCLUSION OR LIMITATION OF INCIDENTAL OR CONSEQUENTIAL DAMAGES, SO THE ABOVE LIMITATIONS OR EXCLUSIONS MAY NOT APPLY. PRODUCTS OR PARTS OF OTHER MANUFACTURERS ATTACHED ARE SPECIFICALLY EXCLUDED FROM THE WARRANTY.

THIS WARRANTY GIVES YOU SPECIFIC LEGAL RIGHTS, AND YOU MAY HAVE OTHER RIGHTS WHICH VARY UNDER THE LAWS OF EACH STATE. IF ANY PROVISION OF THIS WARRANTY IS PROHIBITED OR INVALID UNDER APPLICABLE STATE OR PROVINCIAL LAW, THAT PROVISION SHALL BE INEFFECTIVE TO THE EXTENT OF THE PROHIBITION OR INVALIDITY WITHOUT INVALIDATING THE REMAINDER OF THE AFFECTED PROVISION OR THE OTHER PROVISIONS OF THIS WARRANTY.