

Electro Air Handler

Features

- ECM blower motor
- Heavy duty construction
- Standard Electro Load Control connections
 - Can relate to AC only, if heat is not controlled
- 1½-ton to 5-ton blower speed selection
- Compact cabinet
- Easy access panel doors
- Easy interface with ultraviolet air purifier and humidifier

ECM Variable Speed Blower

Highest efficiency in blower motors, continuous air at very high efficiency, automatically adjusts blower speed to maintain consistent CFM levels regardless of various changes in static pressure levels.

Option, Variable Speed Zone Pump

WarmFlo® controller - a field kit can provide outdoor and plenum temperature sensing to modulate a standard 1/6 HP or less pump. This can ramp up the supply temperature relating to decreased outdoor temperature. Eight temperature/ramp-up ratios are front dial selectable, request part WF-VS2P.

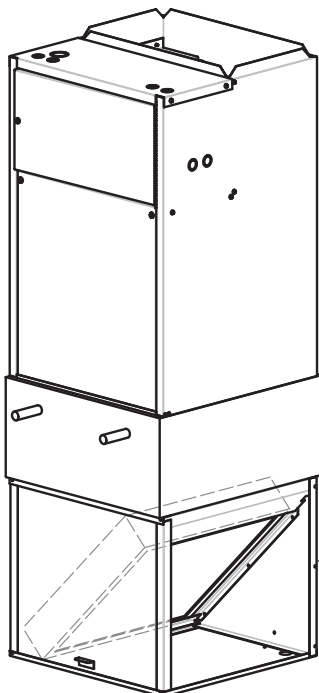

Specifications subject to change without notice, all rights reserved.

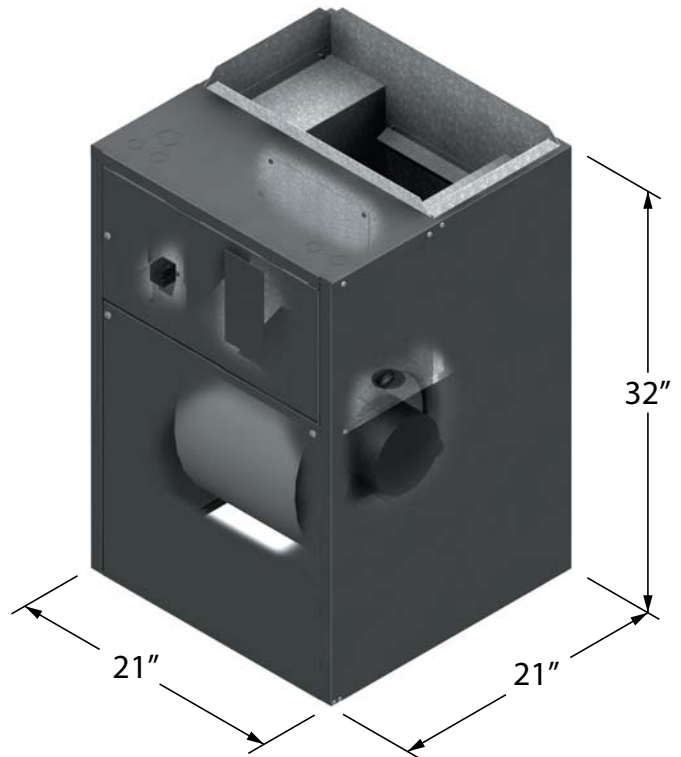

Specifications

Model	kW	Btu/h	Motor	Amps	Volts	Breakers
HE-N-00-21	N/A	N/A	½ HP	8 (max.)	120	N/A

- 21"W x 32"H x 21"D
- ½ HP ECM motor
- 100 lbs.
- 700-1200 CFM

Optional Cabinets

HYDRONICS, HE-WC-21-40

This cabinet includes a water coil as shown. The return air connection must be on the bottom which allows coil draw-through. The inlet for this cabinet is sized for an externally installed packaged return air filter cabinet.

AIR FILTER, HE-IF-21

This cabinet includes a standard 2" or 4" x 20" x 20" pleated filter. The cabinet has adjustable filter rails to accommodate filters that vary in thickness.



ELECTRO INDUSTRIES, INC.

2150 West River Street, PO Box 538, Monticello, MN 55362
763.295.4138 • 800.922.4138 • fax 763.295.4434
sales@electromn.com • www.electromn.com