

# Electro Industries' Industrial Electric Water Boilers

---

Electro Industries' Industrial Boiler is a very compact and an effective solution to retrofitting old, inefficient fossil fuel boilers, or for use in new installations.

Safety is one major benefit of these boilers. Several state electrical jurisdictions are requiring the (optional) Bender Insulation Monitor device (ground fault) for increased operating safety, personal protection and reliability of the boiler. Secondly, there are individual circuit breakers for each heating element, further increasing the safety and reliability of our boilers.

Each boiler also includes built-in digital supply return and outdoor temperature sensors, enabling you to internally set and maintain the correct system design temperature, simplifying the installation process.

## Features & Benefits

- Pressure vessel built in accordance with the requirements of the ASME Boiler and Pressure Vessel Code (National Board and CRN registered)
- Compact, can easily fit through service doors
- High efficiency electric boiler with no combustion waste
- No minimum return water temperature required
- Individual circuit breakers for each heating element
- All boilers come fully assembled; control box is within front door
- Built-in digital temperature sensing; adjustable desired temperature allows the user to set the boiler to operate at a specific supply temperature (set point mode)
- Outdoor reset (can be enabled or disabled)
- Outdoor reset sensing and software (reset mode)
- Operator alarm monitor and control functions including manual resets are in the control box
- All parts within the boiler are rated for 60° C
- Optional remote display - water temperature, set point, percent on, alarm status, estimated GPM. In addition, design includes provisions for phone dialer, Web controller, etc.
- Optional Honeywell T775R temperature control
- 0-10VDC terminal enabling control of boiler via building automation system, etc.
- Software and interface cable for setup, monitoring, and troubleshooting



## Transformer Wiring Configurations

**Standard boiler** - add to building electrical service, 4-wire but no neutral current. All service wiring design, safety and ground fault equipment, NEC special code application, etc. are the responsibility of the installer.

**Standard boiler with option ground fault monitor** - suitable for use with a 3-wire Delta service, dedicated utility transformer (Delta or unbonded/neutral). All control and protection needed to meet NEC Article 250 is included.

## Product Specifications

The electric hot water boiler shall be an Electro Industries, Inc. model number EB-NB-\_\_\_\_\_. The Boiler output shall be \_\_\_\_ Btu/h or \_\_\_\_ kW at \_\_\_\_ volts three phase. Wiring within the main cabinet shall be rated at 75°C or higher. Aluminum or copper conductors may be used for field installed power wiring. The boiler shall include provisions to connect directly to utility load control. The boiler shall include a dedicated 15A 120V single phase control circuit (general service).

As a preferred option the boiler (dependant upon kW) shall be wired using (2) three phase delta feeds without neutral (unbonded neutral) within the dedicated utility transformer XO terminal. All Delta 3-phase require optional Bender fault monitor.

The vessel shall be wrapped with 3" insulation. The vessel shall be enclosed in a 14 gauge fully enclosed cabinet. The cabinet and vessel shall be attached to a 10 gauge structural steel base. The base includes integral fork pockets for easy maneuvering during installation. Both base and cabinet shall be painted with powder coated enamel. The cabinet shall include a full length hinged door with an included lockable T-handle. The inside dead front panel shall include an integral door safety interlock switch.

The vessel shall have a capacity of 40 gallons. The vessel shall be "H" stamped and National Board registered with a working pressure of 30 PSI. The Vessel shall have 3" NPT threaded inlet and outlet nozzles. The outlet nozzle shall be located on the top of the vessel. The inlet nozzle shall be located on the left side of the vessel.

The immersion heating elements shall be installed in the top of the vessel and threaded into vessel for easy servicing (water draw-down not required). The heating elements shall be constructed using incoloy sheathing for long service life. The low-watt density heating elements shall be 30" in length. The cabinet shall have a split cover top for easy access to the heating elements. Contactors used to operate the heating elements shall be rated for 500,000 cycles.

The boiler shall include mounted control enclosure. The control enclosure shall contain all boiler controls and adjustments. Operator is not required to enter main cabinet for resets or other functions. A window shall be included on the door of the control enclosure to permit viewing of monitor and alarm LED's. The control assembly shall include a six function alarm LED. The sequencer shall include provisions for stage rotation. An optional emergency stop switch can be included in the control assembly upon request. The boiler shall include a 5-year limited warranty on the vessel and a 1-year limited warranty on the parts. The boiler shall be fully tested using standard UL834 and shall bear the CSA mark.

### Standard Equipment

- Circuit breakers, each stage
- Manual reset hi-limit - 220° F
- Auto reset limit control - 210° F
- Low water cut-off with manual reset
- ASME pressure relief valve, 30 psi
- Pressure/temperature gauge
- Drain pipe
- 3" NPT inlet and outlet, with inspection opening
- Incoloy sheathed heating elements, vessel top screw-in
- Staging indicator lights, at contactor
- Main supply circuit lugs
- Safety door interlock and lockable door latch

### Control Box includes:

- Contains all boiler controls and adjustments
- Bender fault monitor (optional)
- Manual reset low water cut-off
- Hi-limit reset button
- Temp Sensing & Alarm board
- T775R controller (optional)
- Alarm and alarm LED's
- Sequencer up to 15 stages
- Progressive staging delay time
- 0-10VDC for external boiler control
- Built-in load management controls

# INDUSTRIAL BOILER, EB-NB-\*\*\*-\*\*\*

Hydronic Boilers  
Submittal Data

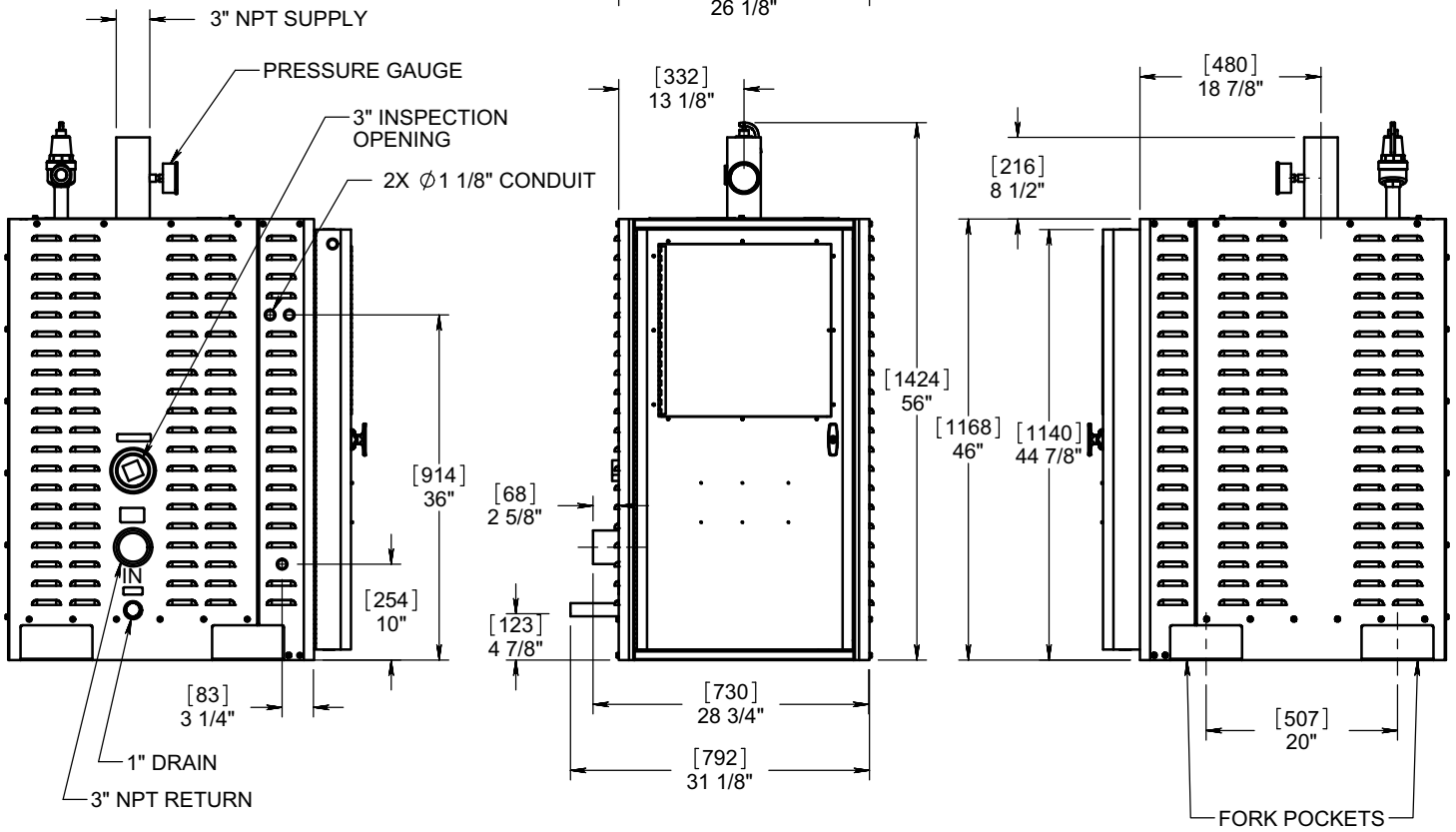
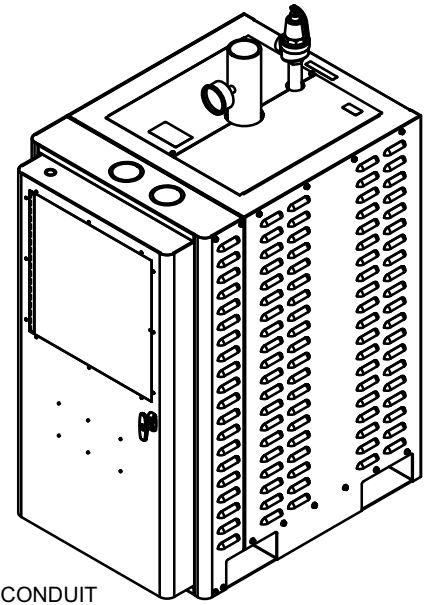
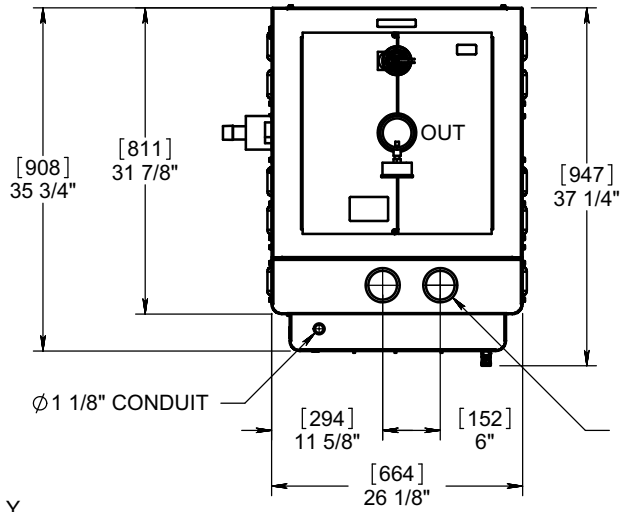

## CLEARANCES

	MINIMUM CLEARANCE FROM COMBUSTIBLE SURFACES		SUGGESTED MINIMUM SERVICE CLEARANCE	
	INCHES	MM	INCHES	MM
BACK	0 INCH	0 MM	0 INCH	0 MM
LEFT	12 INCHES	305 MM	24 INCHES	610 MM
RIGHT	8 INCHES	203 MM	12 INCHES	305 MM
FRONT	24 INCHES	457 MM	36 INCHES	914 MM
TOP	26 INCHES	660 MM	26 INCHES	660 MM

DIMENSIONS ARE:  
[mm]  
IN

## Electric Supply

Model	Volts	kW	Amps 3-Phase		Watts	Element Quantity	Steps	Btu/h Output	Flow Rate @20° ΔT		Boiler Weight
			Feed #1 <sup>†</sup>	Feed #2 <sup>†</sup>					Min GPM	Max GPM	
EB-NB-72-600	600	72	69	-	72,000	6	6 @ 12	245,736	4	21	685
EB-NB-84-600	600	84	81	-	84,000	7	7 @ 12	286,692	4	29	695
EB-NB-108-600	600	108	92	12	108,000	9	9 @ 12	368,604	4	37	700
EB-NB-120-600	600	120	92	23	120,000	10	10 @ 12	409,560	4	41	705
EB-NB-144-600	600	144	92	46	144,000	12	12 @ 12	491,472	4	49	710
EB-NB-160-600	600	160	154	-	160,000	8	8 @ 20	546,080	7	55	695
EB-NB-200-600	600	200	154	38	200,000	10	10 @ 20	682,600	7	68	700
EB-NB-240-600	600	240	154	77	240,000	12	12 @ 20	819,120	7	82	705
EB-NB-300-600	600	300	154	135	300,000	15	15 @ 20	1,023,900	7	102	710
EB-NB-84-480	480	84	101	-	84,000	7	7 @ 12	286,692	4	29	695
EB-NB-108-480	480	108	116	15	108,000	9	9 @ 12	368,604	4	37	700
EB-NB-120-480	480	120	116	29	120,000	10	10 @ 12	409,560	4	41	705
EB-NB-144-480	480	144	116	58	144,000	12	12 @ 12	491,472	4	49	710
EB-NB-160-480	480	160	193	-	160,000	8	8 @ 20	546,080	7	55	695
EB-NB-200-480	480	200	193	48	200,000	10	10 @ 20	682,600	7	68	700
EB-NB-240-480	480	240	193	96	240,000	12	12 @ 20	819,120	7	82	705
EB-NB-300-480	480	300	193	169	300,000	15	15 @ 20	1,023,900	7	102	710
EB-NB-60-208	208	60	167	-	60,000	4	4 @ 15	204,780	5	21	716
EB-NB-75-208	208	75	209	-	75,000	5	5 @ 15	255,975	5	26	721
EB-NB-105-208	208	105	292	-	105,000	7	7 @ 15	358,365	5	36	721
EB-NB-150-208	208	150	292	125	150,000	10	10 @ 15	511,950	5	50	731
EB-NB-180-208	208	180	292	210	180,000	12	12 @ 15	614,340	5	61	737
EB-NB-60-240	240	60	145	-	60,000	4	4 @ 15	204,780	5	20	716
EB-NB-75-240	240	75	181	-	75,000	5	5 @ 15	255,975	5	26	721
EB-NB-105-240	240	105	253	-	105,000	7	7 @ 15	358,365	5	36	721
EB-NB-150-240	240	150	289	73	150,000	10	10 @ 15	511,950	5	51	731
EB-NB-180-240	240	180	289	145	180,000	12	12 @ 15	614,340	5	61	737

<sup>†</sup>Actual calculated amps, not service rating.

## Options

**EB-N-GFM-KIT** - Ground fault monitor kit. Add this kit to your order for installations utilizing a dedicated utility transformer designed to be used as a 3-wire Delta service, with unbonded neutral.

**5600** - Honeywell, T775R, electronic stand-alone operating control.



Specifications subject to change without notice, all rights reserved.

07/21/2010



**ELECTRO INDUSTRIES, INC.**

2150 West River Street, PO Box 538, Monticello, MN 55362  
763.295.4138 • 800.922.4138 • fax 763.295.4434  
sales@electromn.com • www.electromn.com

BL801